

Conveyor Systems

Product Catalogue

Technical Information
Component Specification



NIKO ... Quality in Motion

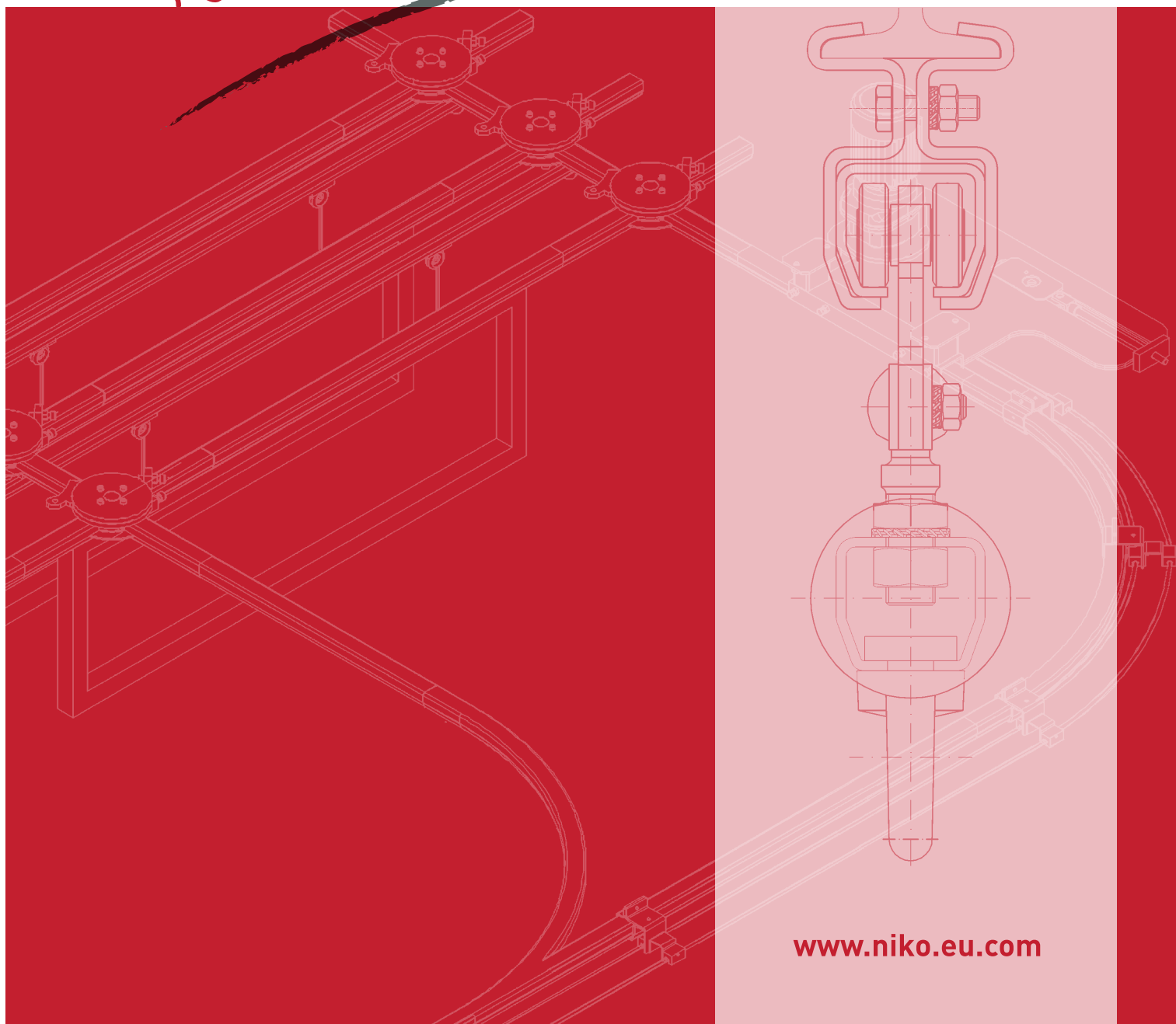

www.niko.eu.com

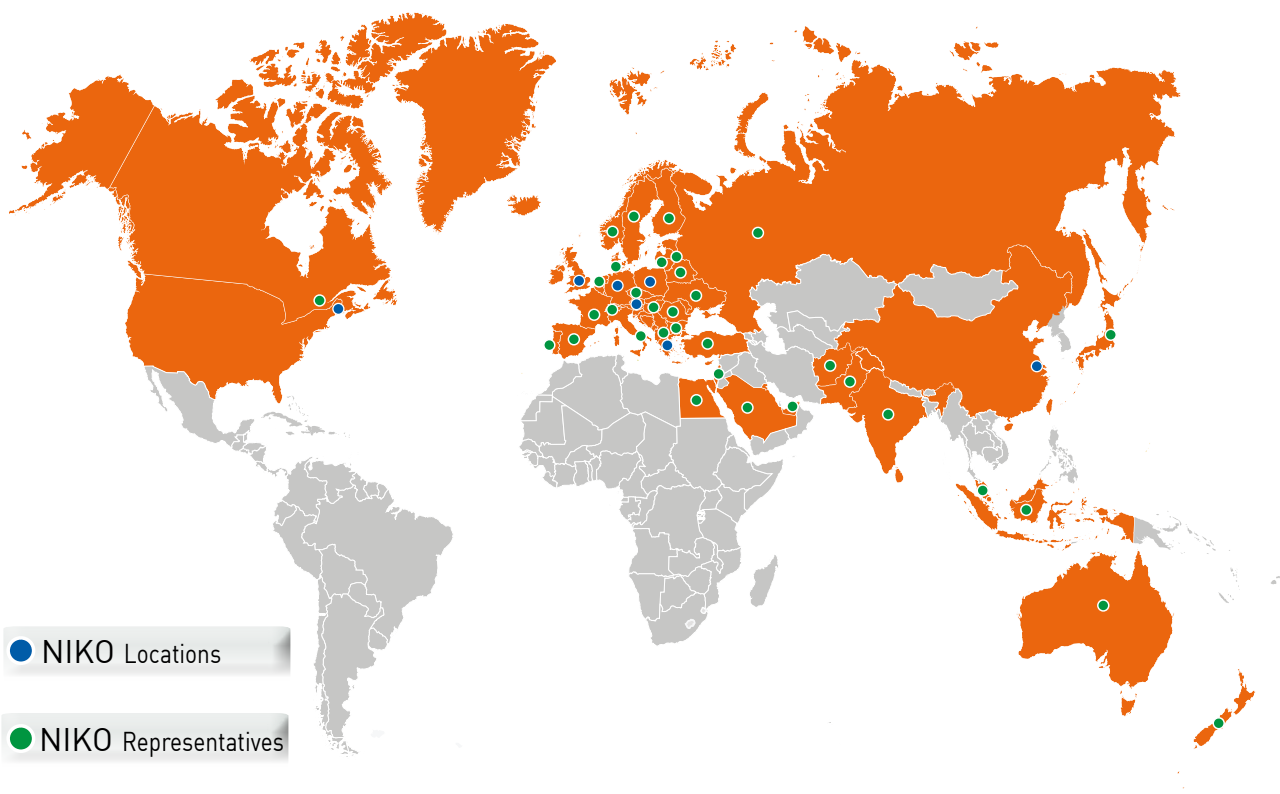

● NIKO Locations

● NIKO Representatives

Company Profile

Established in 1972, NIKO is focused on designing developing, producing and marketing high quality sliding door fittings and overhead conveyor systems at the right price. Over 90 % of our products are exported to more than 60 countries worldwide with offices and warehouses in 7 countries worldwide.

Our program range includes more than 2.000 different assemblies & components. Our team of highly qualified engineers are continually working to improve our current product portofolio & extend it according to market requirements.

NIKO enforces a continuous quality control program and is certified according to ISO:9001 and ISO:14001.



Index

Introduction	Page	4
Overhead conveyors configuration example	Page	5
Painting lines examples	Page	6-8
Power chain conveyor	Page	9
Crane bridge wagon	Page	9
Application photos	Page	10-11
Track profiles	Page	12
Track bends	Page	13
Brackets & support joints	Page	14-23
Bearing options	Page	23
Trolleys - Flight bars	Page	24-39
Switches	Page	40-48
Ring support bracket - Articulation joint	Page	48
Directional stoppers	Page	49
Stoppers - Dilation joint	Page	50
Swivel units	Page	50-51
Bridge Interlock	Page	52
Track transfer assembly	Page	53
Drop-lift units	Page	54-55
Stainless steel series 304/316	Page	56-62

NIKO Overhead Conveyor Systems – a versatile and economic solution for loads up to 2.000kg.



The “NIKO” conveyor system provides an economic and flexible solution in conveyor systems for loads up to 2.000 kg. The manual operation of our systems can also be combined with our power chain conveyor in order to power segments or the entire conveyor.

Versatile and reliable overhead handling can be achieved for a variety of applications using the NIKO modular design. Simple to install and easy to expand or relocate according to future requirements. The robust design of our components and the high standards of manufacturing guarantee long life with little or no maintenance requirements. Our program range consists of sliding door fittings, overhead conveyor systems, festoon systems, fall arrest systems and light cranes.

Main Characteristics

- ✓ 5 different profiles and more than 1.000 components to choose from in order to find the best value for money and appropriate solution.
- ✓ Modular design allows for extension and relocation.
- ✓ Possibility to upgrade existing manual conveyors to power solutions with minimal conversion time.
- ✓ Steel components available in gold and silver finish. Stainless steel components are available upon request.
- ✓ Motorised drop lift units reduce product damage and potential injuries to workers.
- ✓ Long life and low maintenance achieved by dust self-cleaning enclosed track profiles and maintenance free bearings.
- ✓ Engineering consultation support is provided in order to find the best solution to every handling problem.

NIKO conveyors are used extensively in applications of painting, rethreading tyres, assembly, production and storage.

Overhead Conveyors Configuration Example

- ✓ Modular system design to accommodate any solution necessary.
- ✓ Minimal maintenance required.

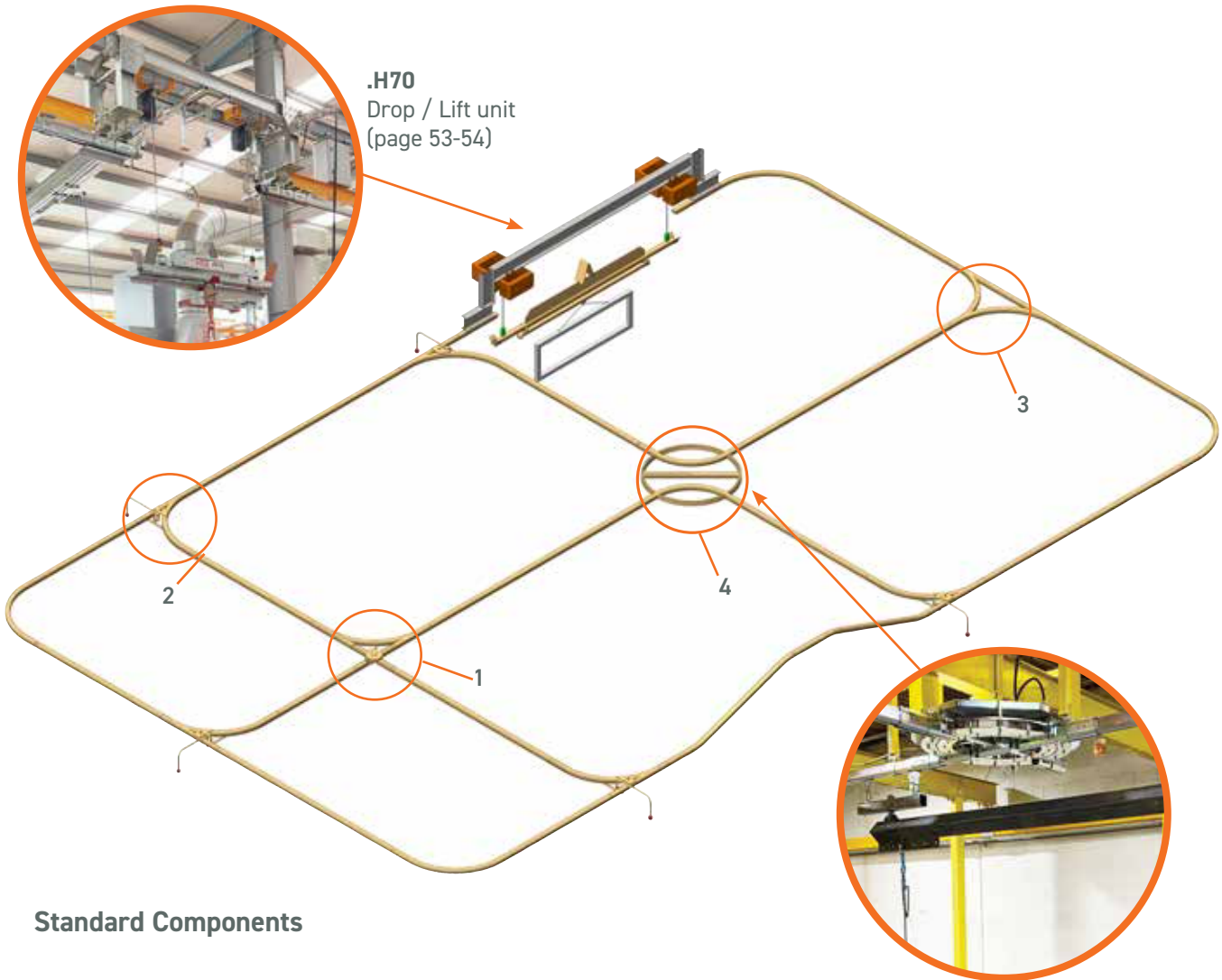

CONVEYOR SYSTEMS

Standard Components



1 **.A17**
Tongue Switch with Pneumatic turn table (page 40)

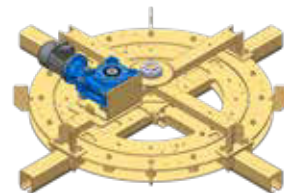

4 **EL/.A41**
Multiple Turn Table Switch (page 46)



2 **.A46**
Tongue Switch (page 43)



3 **.A15**
Tongue Switch with two 90° bends (page 43)

Painting Line - example 1

- ✓ High productivity achieved utilising pneumatic turntables.
- ✓ Minimum space requirements.
- ✓ Power side transfer through the oven or painting booth.

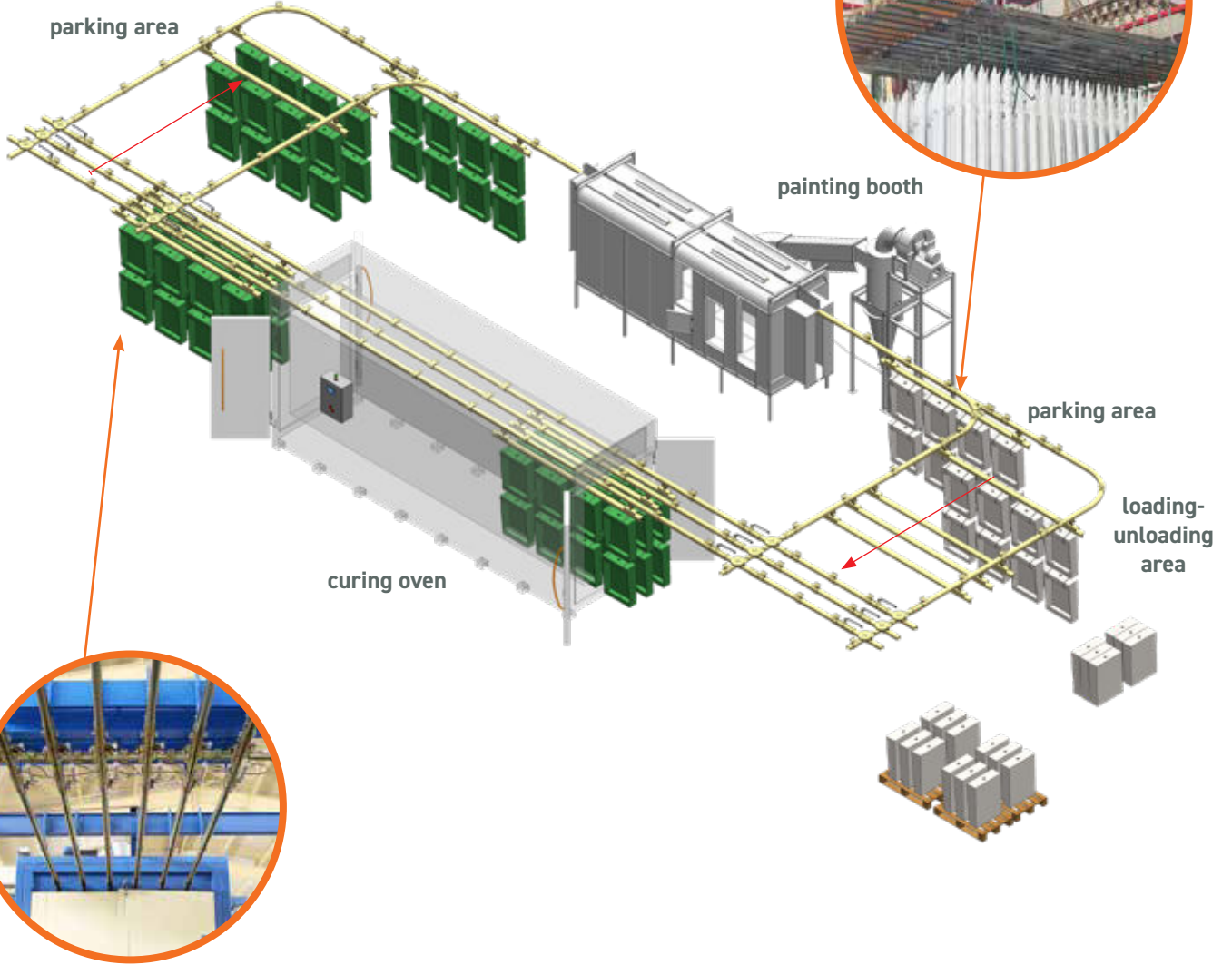

Standard Components



.A44
Pneumatic
Turn Table Switch
(page 48)

Painting Line - example 2

- ✓ Minimum space requirements.
- ✓ Ergonomically designed crane wagons.

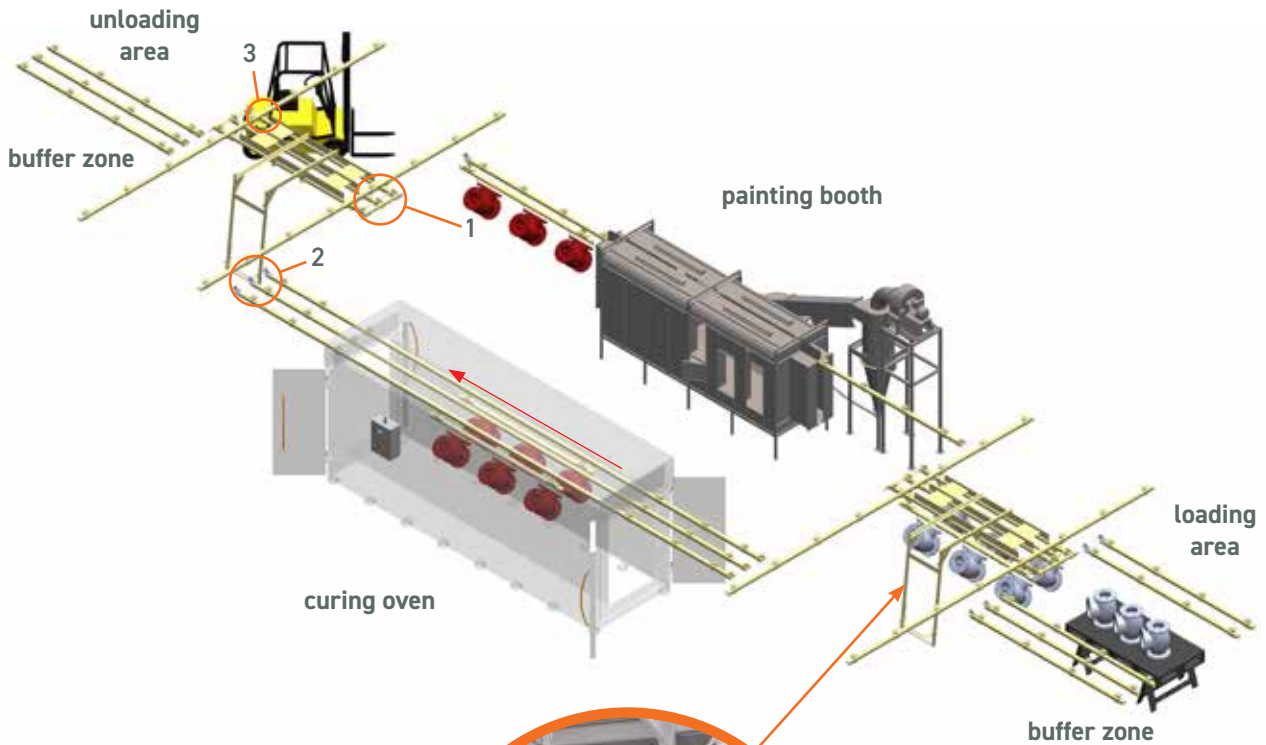

CONVEYOR SYSTEMS

Standard Components

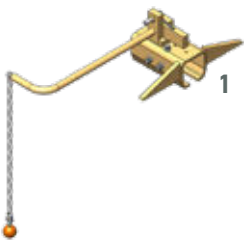

1 **.H01**
Bridge Interlock, Part 1
(page 52)

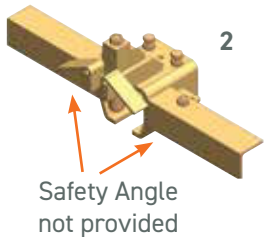

2 **.H02**
Bridge Interlock, Part 2
(page 52)



3 **.T54**
End carriage with
track joint
(C2 Product
Catalogue)

Painting Line - example 3

- ✓ The best value for money solution.
- ✓ High productivity achieved utilising mechanically automatic switches.
- ✓ Power Side Transfer through the oven or painting booth.

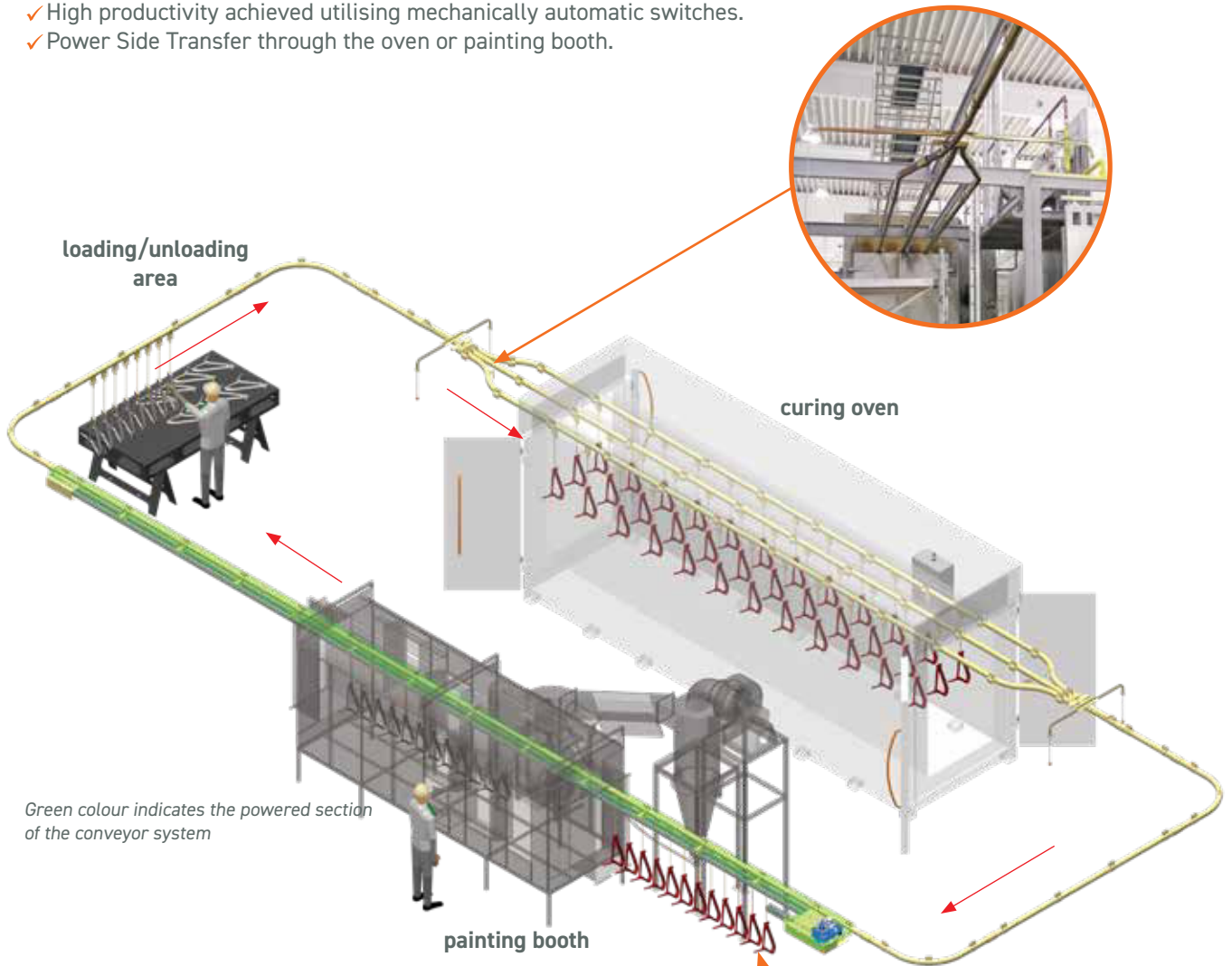

CONVEYOR SYSTEMS

Standard Components



1. .A35 with .DL Swivel Switch with Double Pulling chain (page 42)

2. .T47 These 4-wheel trolley are most commonly used for power chain driven systems. (page 32)



Power Chain Conveyor

A chain conveyor can be installed parallel to the conveyor carrying the load in order to power the movement. Powered movement can be achieved not only in straight lines but also in bends making it possible to have a completely powered system.

A typical application would be to power the movement through the ovens or painting booths and have the parking areas free in order to load and unload the products in adequate time. The benefits of the power chain conveyor are its competitive price, quiet operation and the fact that it can be added to a manual conveyor at a future stage.

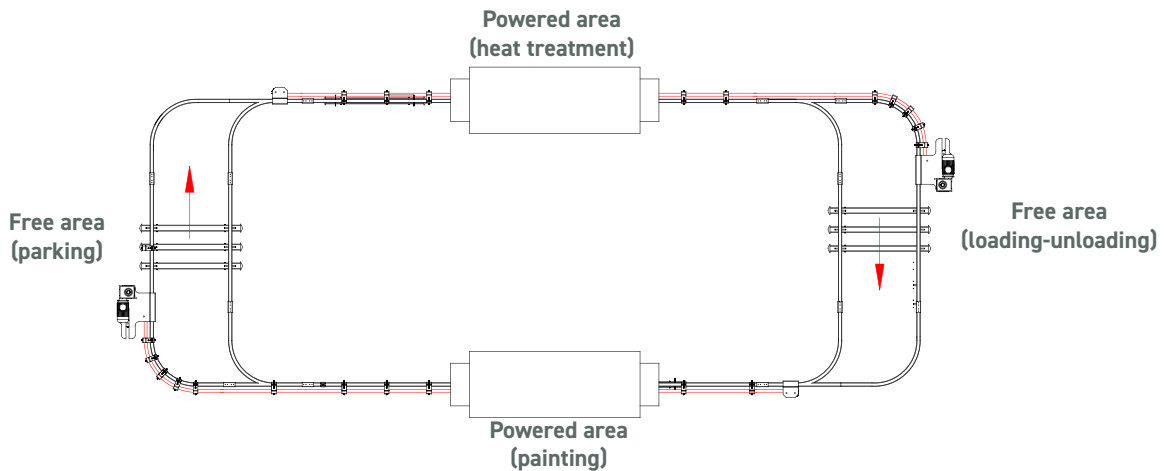
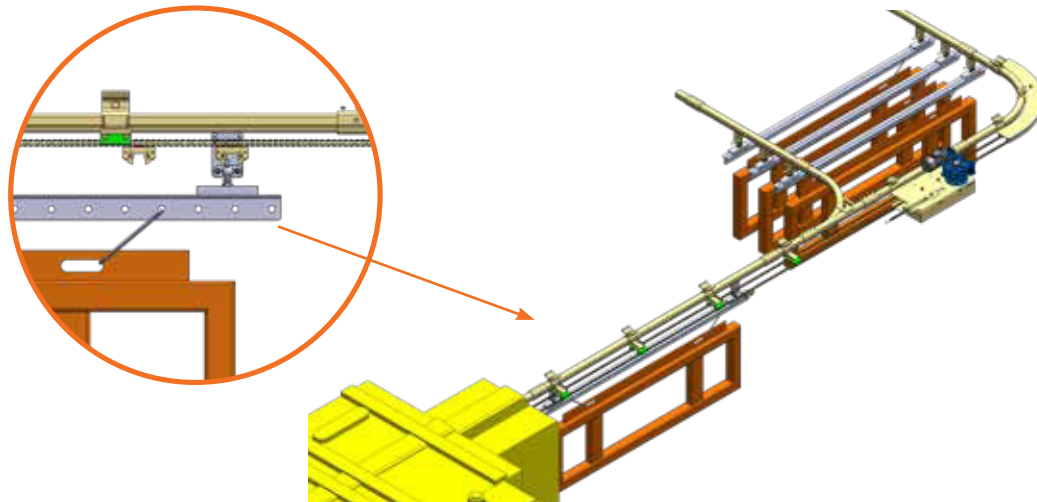

Crane Bridge Wagon

Crane bridge wagons with multiple lines are a popular solution when cross travel is required. They consist of the bridge with multiple lines, interlocks and an operating handle.

For conveyor systems with crane bridge wagon using bridge interlocks not all types of trolleys are suitable. Please ask us for more information.

.H02

Bridge Interlock, Part 1
(page 52)

.H01

Bridge Interlock, Part 2
(page 52)

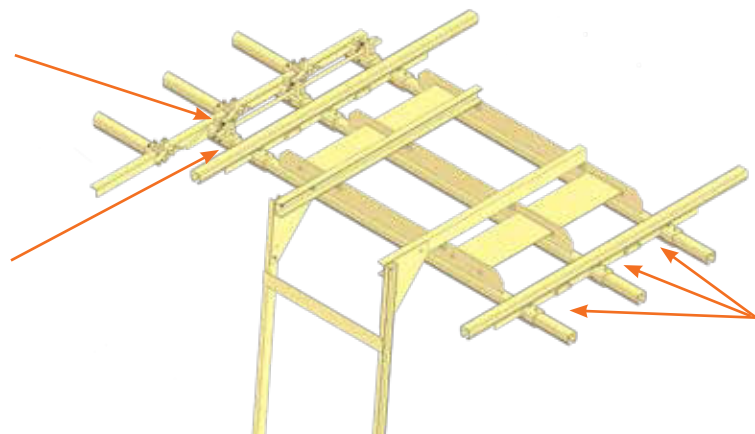

.T54

End carriage with track joint
(C2 Product Catalogue)



CONVEYOR SYSTEMS

Application Photos



CONVEYOR SYSTEMS



Conveyor Systems

We reserve the right for technical amendments without obligation.
The product pictures and drawings depicted in this catalogue do not always reflect all available sizes.

Component Specifications

NIKO Track Profiles

Our wide range of 6 Track profile sizes can accommodate loads up to 2.000 kg. The NIKO enclosed track tapered design allows correct alignment of the trolleys and reduces the possibility of dust build up. This ensures the smooth running of the trolleys and the long life of the conveyor system. NIKO conveyors require only 1-4% force of the weight being lifted in order to operate. For use in special environments we can also offer NIKO tracks & components in stainless steel grade 304 and 316.

NIKO Profile No.	Dimensions			
	h (mm)	b (mm)	d (mm)	s (mm)
21.000	28	30	8	1,75
23.000	35,00	40,00	11,00	2,75
24.000	43,50	48,50	15,00	3,20
25.000	60,00	65,00	18,00	3,60
26.000	75,00	80,00	22,00	4,50
27.000	110,00	90,00	25,00	6,50

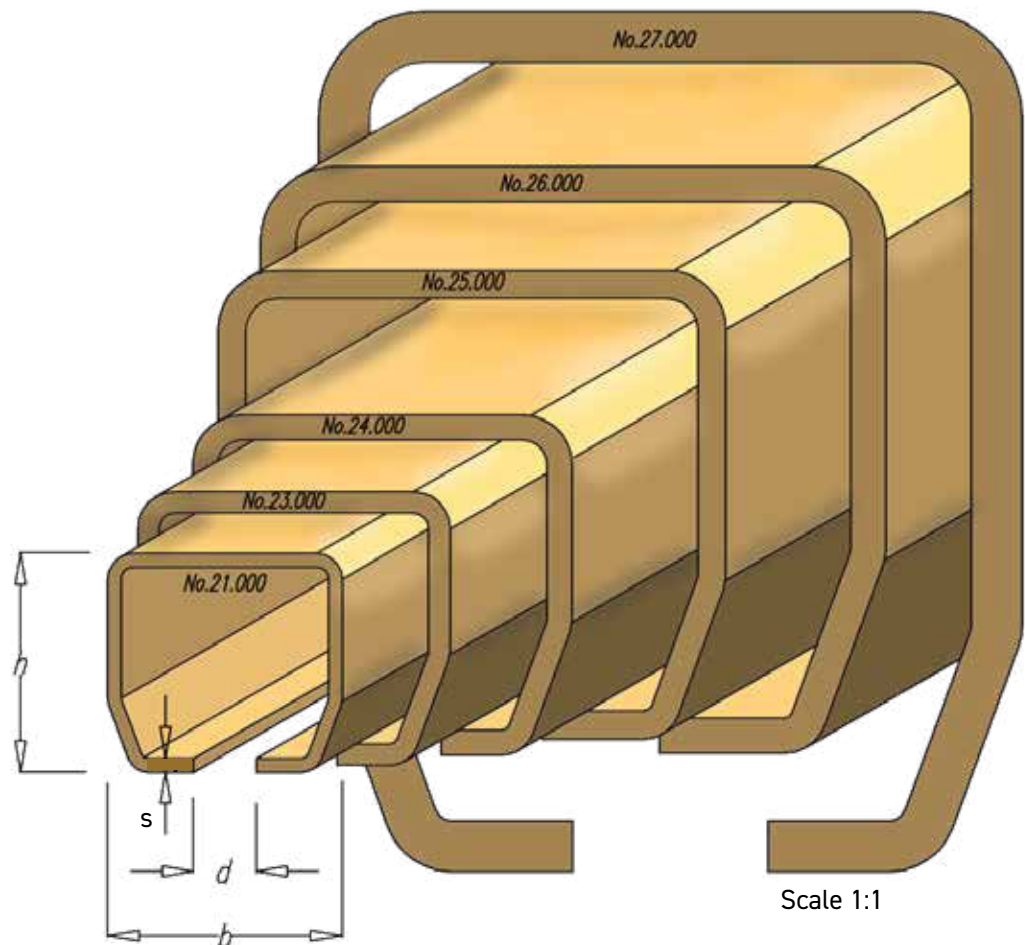

Track Bends

NIKO Profile No.	21.000	23.000	24.000	25.000	26.000	27.000
Track bend 90° No.	21.C06	23.C07	24.C06	25.C06	26.C08	27.C10
a (mm)	490±20	460±20	550±20	550±20	900±20	690±20
R (mm)	650±10	690±15	580±15	580±15	770±20	1035±20
L (mm)	2000	2000	2000	2000	3000	3000

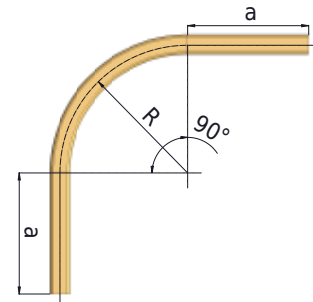

NIKO Profile No.	21.000	21.000	21.000	23.000	24.000	
Track bend 90° No.	21.C02	21.C03	21.C04	23.C04	24.C04	24.C09
a (mm)	590±20	510±20	690±20	690±20	650±20	540±20
R (mm)	205±10	300±10	400±10	400±15	440±15	905±15
L (mm)	1500	1500	2000	2000	2000	2500

NIKO Profile No.	21.000		23.000	24.000
Track bend 60° No.	21.C12	21.C14	23.C14	24.C14
a (mm)	640±20	790±20	790±20	770±20
Track bend 45° No.	21.C22	21.C24	23.C24	24.C24
a (mm)	670±20	840±20	840±20	830±20
Track bend 30° No.	21.C32	21.C34	23.C34	24.C34
a (mm)	700±20	900±20	900±20	890±20
R (mm)	205±10	400±10	400±15	440±15
L (mm)	1500	2000	2000	2000

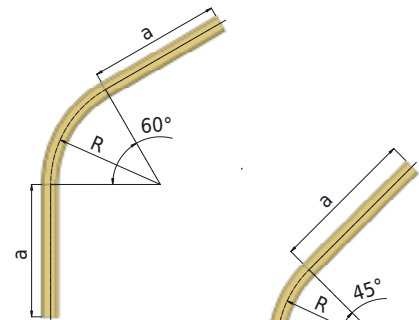

NIKO Profile No.	21.000	23.000	24.000		25.000	26.000	27.000
Track bend 60° No.	21.C16	23.C17	24.C16	24.C19	25.C16	26.C18	27.C20
a (mm)	660±20	640±20	700±20	530±20	700±20	600±20	960±20
Track bend 45° No.	21.C26	23.C27	24.C26	24.C29	25.C26	26.C28	27.C30
a (mm)	750±20	730±20	770±20	640±20	770±20	700±20	1090±20
Track bend 30° No.	21.C36	23.C37	24.C36	24.C39	25.C36	26.C38	27.C40
a (mm)	830±20	820±20	850±20	760±20	850±20	800±20	1230±20
R (mm)	650±10	690±15	580±15	905±15	580±15	770±20	1035±20
L (mm)	2000	2000	2000	2000	2000	2000	3000

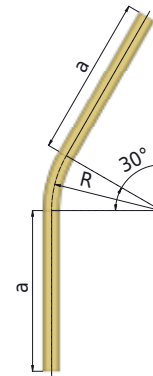

NIKO Profile No.	21.000		23.000		24.000		25.000	26.000
Track bend 180° No.	21.C64	21.C66	23.C64	23.C67	24.C64	24.C66	25.C66	26.C68
a (mm)	250±20		200±20		300±20		300±20	130±20
R (mm)	400±10	650±10	400±10	690±10	440±10	580±10	580±10	770±10

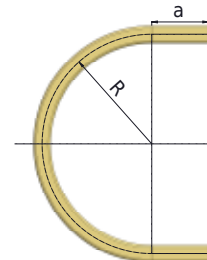

NIKO Profile No.	23.000	24.000	25.000	26.000
Vertical bend 20° /incline	23.C50	24.C50	25.C50	26.C50
Vertical bend 20° / decline	23.C51	24.C51	25.C51	26.C51
a (mm)	220±20	220±20	220±20	220±20
R (mm)	600±20	600±20	600±20	600±20
L (mm)	610	665	670	700

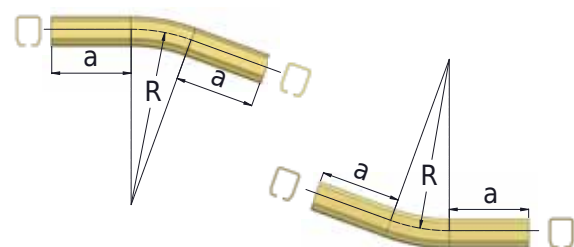

Splice Joint

.B49

The track sections are joined using the track joint by tightening the top screws first then aligning the profiles by means of the side screws.

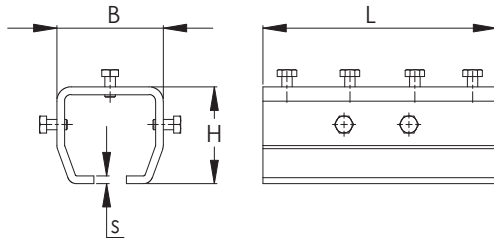

NIKO Profile No.	21.000	23.000	24.000	25.000	26.000	27.000
Part.No.	21.B49	23.B49	24.B49	25.B49	26.B49	27.B49
L (mm)	85	120	150	180	200	250
H (mm)	36	44	54	75	94	133
B (mm)	38	50	61	81	100	116
s (mm)	3	4	4,5	6	8	10

Support Bracket

.B00/.B50

This bracket can be used and adapted for specific applications where standard supports are unsuitable. (plain-unplated and zinc plated)

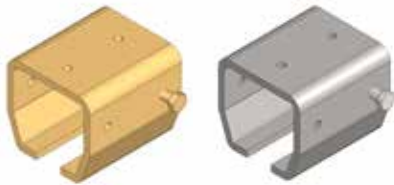

.B00

.B50

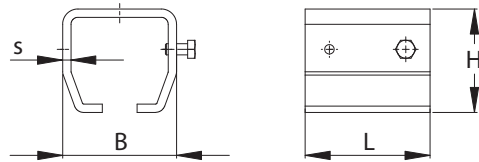

NIKO Profile No.	21.000	23.000	24.000	25.000	26.000	27.000
Part No. Zinc plated	21.B00	23.B00	24.B00	25.B00	26.B00	27.B00
Part No. Black	21.B50	23.B50	24.B50	25.B50	26.B50	27.B50
L (mm)	40	56	68	90	110	120
H (mm)	36	44	54	75	94	133
B (mm)	38	50	61	81	100	116
s (mm)	3	4	4,5	6	8	10

Wall Support Bracket

.B01

This kind of support is used for mounting the track directly on to a wall as well as for other constructions with mounting bolts.

26.-27.B01

21.-25.B01

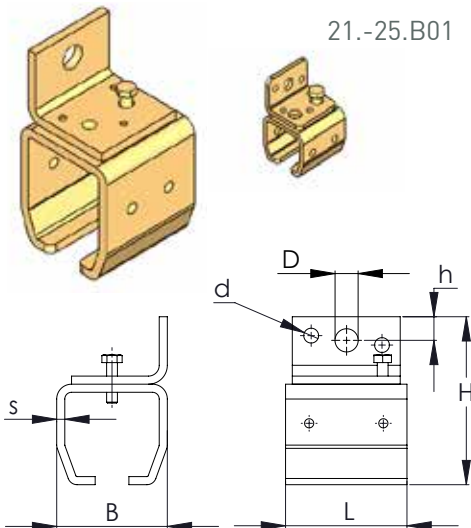

NIKO Profile No.	21.000	23.000	24.000	25.000	26.000	27.000
Part No.	21.B01	23.B01	24.B01	25.B01	26.B01	27.B01
B (mm)	38	50	61	81	100	116
H (mm)	60	79	95	123	156	205
L (mm)	40	56	68	90	110	120
D (mm)	8	11	13	17	22	27
h (mm)	10	13	16	18	25	32
d (mm)	5,2	6,2	8,2	11	-	-
s (mm)	3	4	4,5	6	8	10

Ceiling support bracket

.B02

This bracket is designed for bolting direct to overhead steelwork or ceiling.

It is not recommended to be used in combination with switches due to limited height for the switch levers to operate.

NIKO Profile No.	21.000	23.000	24.000	25.000	26.000	27.000
Part No.	21.B02	23.B02	24.B02	25.B02	26.B02	27.B02
B (mm)	90	115	130	171	210	260
H (mm)	39	50	60	81	104	145
h (mm)	40	56	68	90	110	120
D (mm)	8	11	13	17	22	22
d (mm)	5,2	6,2	8,2	11	-	-
L (mm)	64	81	94	124	148	178,5
s (mm)	3	4	4,5	6	8	10
l (mm)	7	8	8	10	12	23,5
s1 (mm)	3	4	5	6	10	12

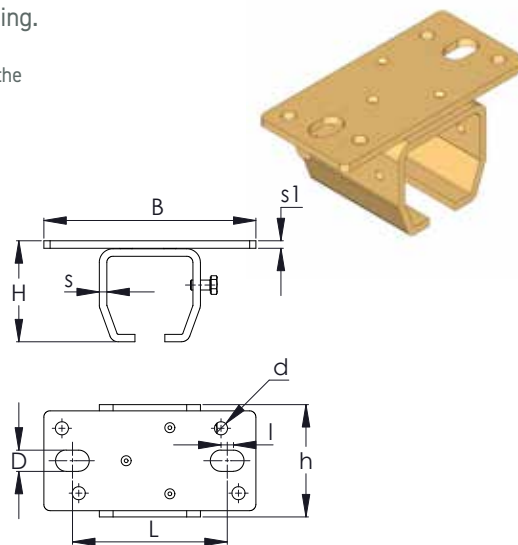

Split support bracket

This bracket is generally used for variable height configurations.

It is suitable for supporting the bend section of bends and switches.
Support at the center of the bend section.

NIKO Profile No.	21.000	23.000	24.000	25.000	26.000	27.000
Part No.	21.B03	23.B03	24.B03	25.B03	26.B03	27.B03
B (mm)	36	48	57	77	96	110
H (mm)	65	78	88	131	150	180
L (mm)	40	50	50	90	110	120
h (mm)	47	60	70	94	112	148
s (mm)	3	4	4	6	8	10
e (mm)	6	8	8	10	10	15
D (mm)	M10	M12	M12	M16	M16	M16
l (mm)	-	-	-	-	-	80

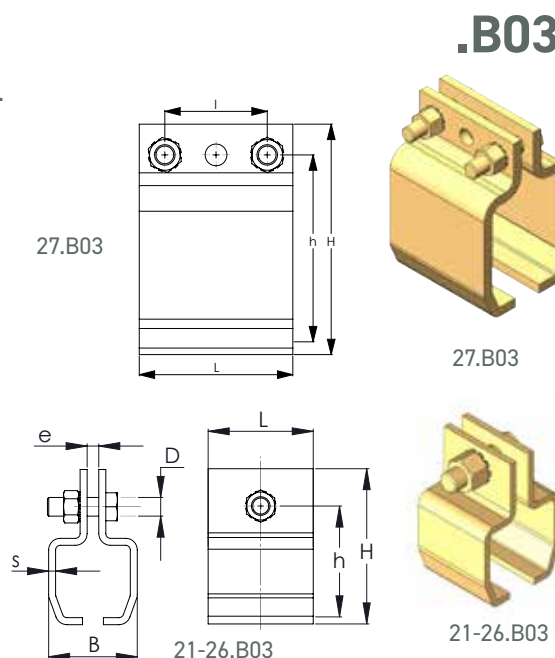

CONVEYOR SYSTEMS

Split support bracket No. B03 & plate with welded-on threaded rod

.B13

NIKO Profile No.	23.000	24.000	25.000	26.000	27.000
Part No.	23.B13	24.B13	25.B13	26.B13	27.B13
B (mm)	48	57	77	96	110
L (mm)	50	50	90	110	120
H (mm)	170	180	230	288	340
d (mm)	M12	M12	M16	M16	M16
D (mm)	M16	M16	M20	M20	M30

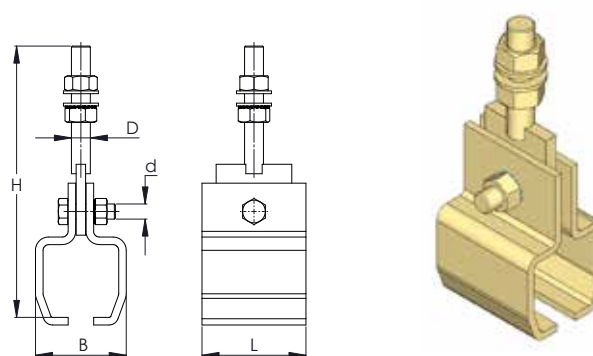

Adjustable Bracket

.B04

This allows us to adjust the height of the rails and to correct any misalignments.

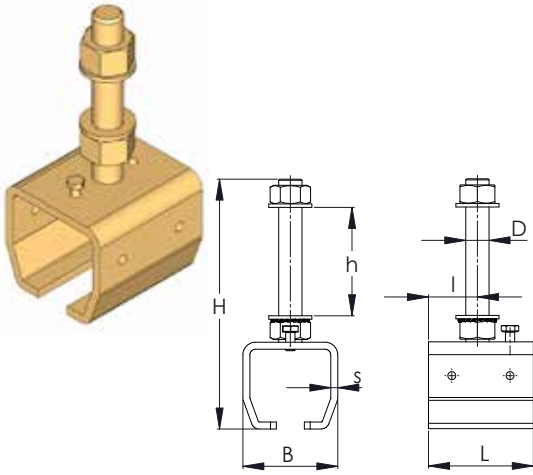

NIKO Profile No.	21.000	23.000	24.000	25.000	26.000	27.000
Part No.	21.B04	23.B04	24.B04	25.B04	26.B04	27.B04
B (mm)	38	50	61	81	100	116
H (mm)	100	135	146	215	295	348
L (mm)	40	56	68	90	110	120
D (mm)	M10	M16	M16	M20	M20	M30
h max (mm)	32	50	55	93	140	140
s (mm)	3	4	4,5	6	8	10
l (mm)	16	20	30	40	50	43

Adjustable wall bracket

.B05

This is used in combination with the .B04 adjustable bracket and is usually mounted on the wall.

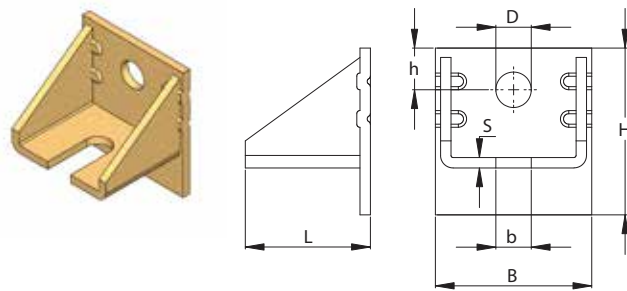

NIKO Profile No.	21.000	23./24.000	25./26.000
Part No.	21.B05	24.B05	26.B05
B (mm)	50	75	90
H (mm)	40	80	110
L (mm)	49	60	98
s (mm)	5	5	8
b (mm)	10,5	17	21
D (mm)	13	17	18
h (mm)	15	20	26

Double adjustable wall bracket

.B06

It can accommodate two .B04 adjustable brackets.

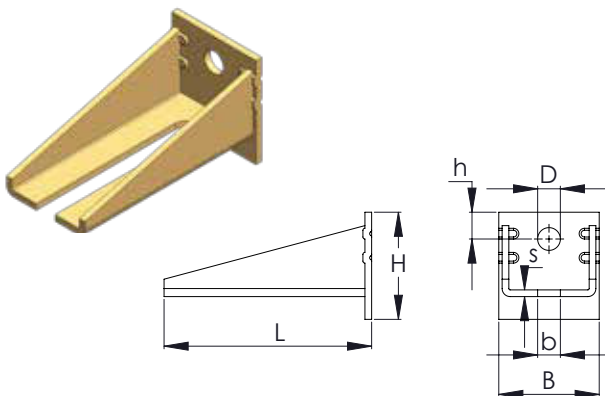

NIKO Profile No.	21.000	23./24.000	25.000	26.000	27.000
Part No.	21.B06	24.B06	25.B06	26.B06	27.B06
B (mm)	60	75	90	90	90
H (mm)	50	80	110	110	110
h (mm)	15	20	26	26	26
L (mm)	100	155	208	208	208
s (mm)	6	5	8	8	8
b (mm)	10,5	17	21	21	32
D (mm)	13	17	18	18	22

21.B05

21.B06

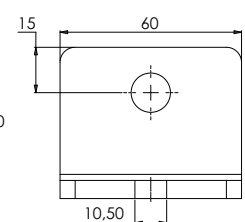
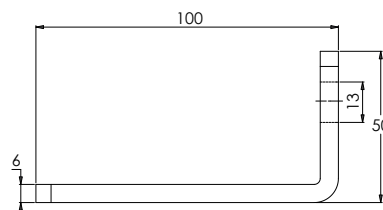
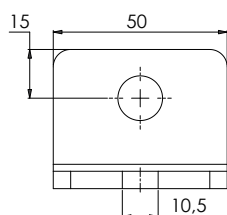
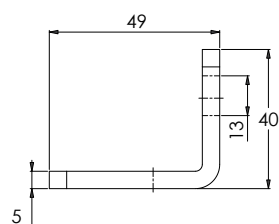

Ceiling Support Joint

.B30

This is a combination of a ceiling support and a splice joint.

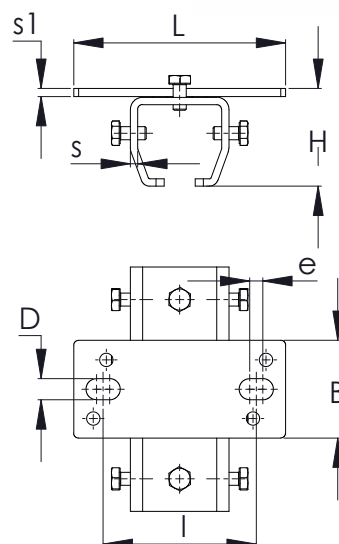

NIKO Profile No.	21.000	23.000	24.000	25.000	26.000	27.000
Part No.	21.B30	23.B30	24.B30	25.B30	26.B30	27.B30
L (mm)	90	115	130	171	210	260
H (mm)	39	50	60	81	104	145
s (mm)	3	4	4,5	6	8	10
B (mm)	40	50	60	80	100	120
e (mm)	7	8	8	10	12	23,5
l (mm)	64	81	94	124	148	178,5
D (mm)	8	11	13	17	22	22
s1 (mm)	3	4	5	6	10	12

Height Adjustable Support Joint

.B11

This is a combination of a height adjustable bracket and a splice joint.

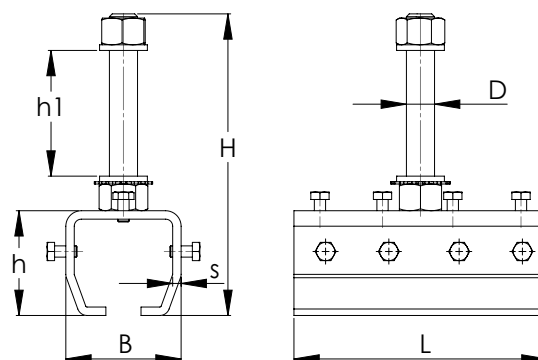
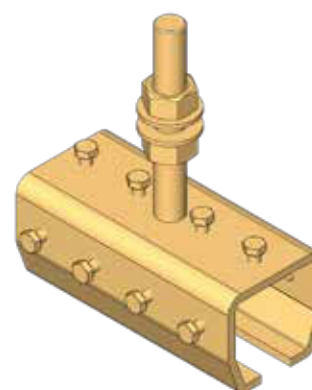

NIKO Profile No.	21.000	23.000	24.000	25.000	26.000	27.000
Part No.	21.B11	23.B11	24.B11	25.B11	26.B11	27.B11
B (mm)	38	50	61	81	100	116
H (mm)	100	135	146	215	295	348
D (mm)	M10	M16	M16	M20	M20	M30
L (mm)	85	120	150	180	200	250
h (mm)	36	44	54	75	94	133
h1 max (mm)	32	50	55	93	140	140
s (mm)	3	4	4,5	6	8	10

CONVEYOR SYSTEMS

Split Suspension Bracket

.B08/.B26

This bracket is used for mounting directly to the underside flange of a parallel I beam.

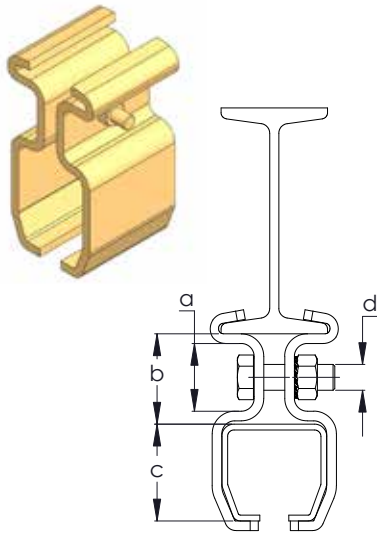

NIKO Profile No.	23.000	24.000	25.000	26.000	27.000
Dimension a in mm.	25	25	42	45	66
Dimension b in mm.	34	34	56	63	90
Dimension c in mm.	35	43.5	60	75	110
Dimension d in mm.	9 Φ	9 Φ	17 Φ	17 Φ	17 Φ
Screw type	M8x30	M8x30	M16x50	M16x50	M16x50
Material	50x4	50x4	90x6	110x8	120x10
Split Suspension Bracket Joist IPN DIN 1025					
For IPN 80x42 (IPE 80)	23.B08	24.B08			
For IPN 100x50 (IPE 80)	23.B10	24.B10	25.B10		
For IPN 120x58 (IPE 100)	23.B12	24.B12	25.B12		
For IPN 140x66 (IPE 120)	23.B14	24.B14	25.B14		
For IPN 160x74 (IPE 140)		24.B16	25.B16	26.B16	
For IPN 180x82 (IPE 160)		24.B18	25.B18	26.B18	
For IPN 200x90 (IPE 180)		24.B20	25.B20	26.B20	27.B20
For IPN 220x98 (IPE 200)			25.B22	26.B22	27.B22
For IPN 240x106 (IPE 220)			25.B24	26.B24	27.B24
For IPN 260x113 (IPE 240)			25.B26	26.B26	27.B26

**It is suitable for supporting the bend section of bends and switches.
Support at the center of the bend section.*

I-Beam girder clamp

.B37

This item is used for clamping the adjustable suspension bracket to the support steelwork and is supplied with bolt and square nut.

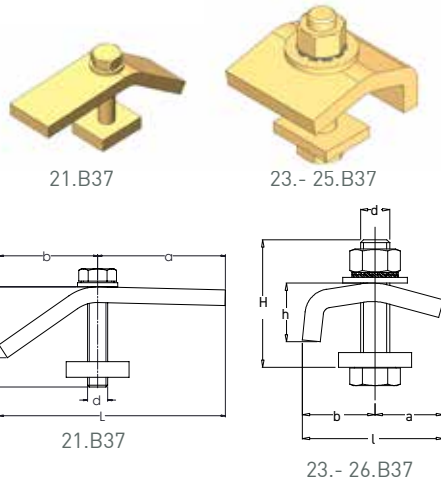

NIKO Profile No.	21.000	23./24.000	25./26.000
Part No.	21.B37	23.B37	25.B37
l (mm)	90	62	80
a (mm)	50	30	40
b (mm)	40	32	40
h (mm)	26	24	30
d (mm)	M8	M12	M16
H (mm)	40	60	70

Girder clamp (heavy duty)

.Z37

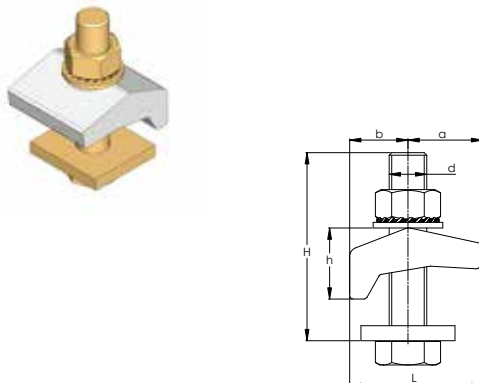

NIKO Profile No.	21.000	23./24.000	25./26.000	27.000
Part No.	21.Z37	23.Z37	25.Z37	27.Z37
H (mm)	50	60	70	100
a (mm)	20	24	32	40
b (mm)	16	19	25	31
d (mm)	M10	M12	M16	M20
h (mm)	20	23	30	38
L (mm)	36	43	57	71

Adjustable Suspension Bracket

.B39

This item is used for clamping the adjustable suspension bracket to the support steelwork and is supplied with bolt and square nut.

NIKO Profile No.	23./24.000	25.000	26.000
Bracket No.	23.B39	25.B39	26.B39
H max (mm)	375	585	600
H min (mm)	265	410	425
d (mm)	M12	M16	M16

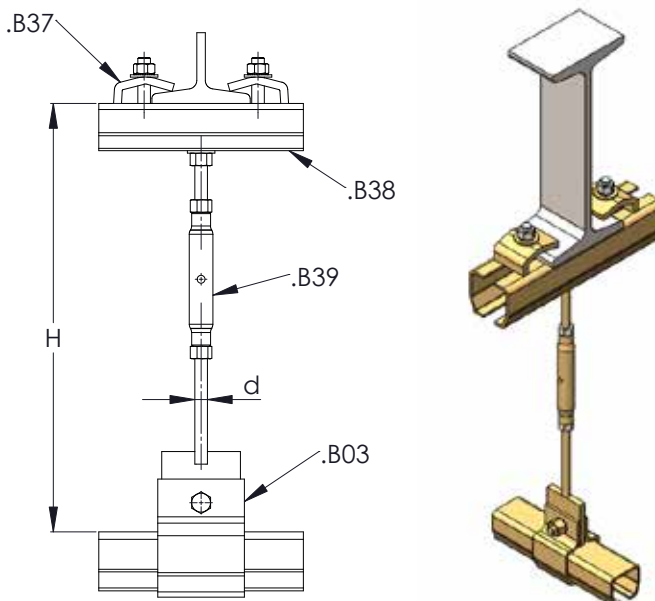

Adjustable Suspension Bracket

.B38

These brackets are designed to accommodate variations in support steelwork distances relative to the track level. They are normally used in conjunction with the adjustable suspension brackets type .B37.

NIKO Profile No.	23.000	24.000	25.000	26.000
Bracket No.	23.B38	25.B38		
L (mm)	198	250		
a (mm)	76	80		
d (mm)	12,5	18		
H (mm)	35	60		

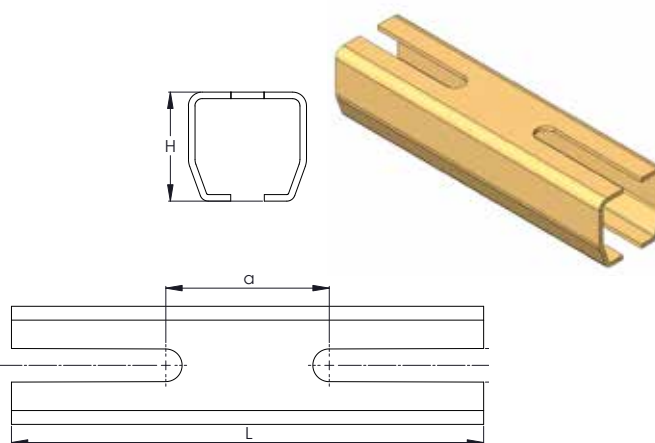

Split Suspension Bracket

.B40

This is normally connected with a steel plate to the bracket B03.

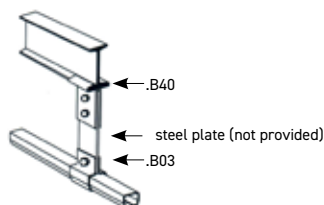

NIKO Profile No.	24.000	24.000 & 25.000	25.000 & 26.000			
Part No.	24.B40	24.B40	26.B40			
Profile DIN 1025 IPN	100	120	140	160	180	200
X (mm)	8	16	24	14	22	30
a (mm)	33	33		40		
b (mm)	45	45		45		
d (mm)	M12	M12		M16		
H (mm)	98	98		110		

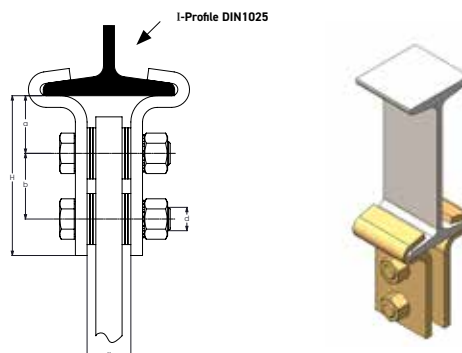

CONVEYOR SYSTEMS

Adjustable Bracket with Ceiling Support

.B44

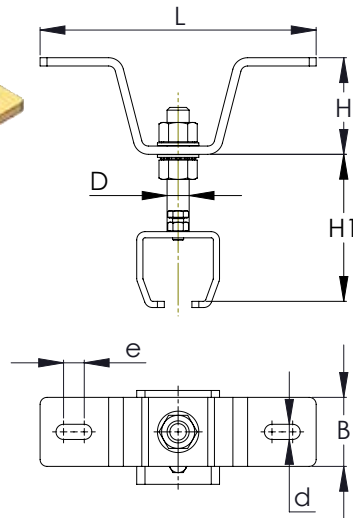
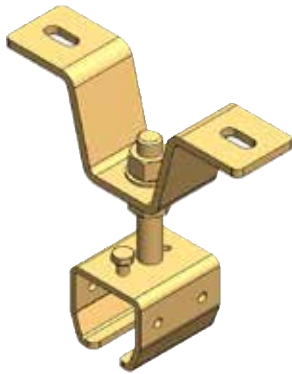

NIKO Profile No.	23.000	24.000	25.000	26.000	27.000
Part No.	23.B44	24.B44	25.B44	26.B44	27.B44
B (mm)	50	50	50	80	80
H (mm)	70	70	70	100	100
L (mm)	200	200	200	280	300
D (mm)	M16	M16	M20	M20	M30
e (mm)	15	15	15	18	20
d (mm)	11	11	11	21	21
H1 max (mm)	100	110	175	255	300
H1 min (mm)	50	55	85	115	160

Ceiling Support

.Z08

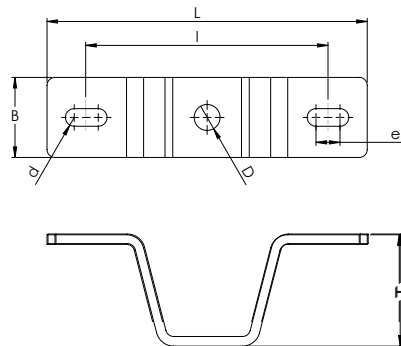
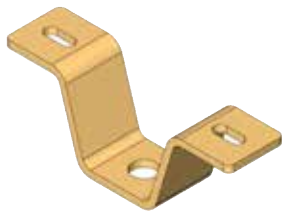

NIKO Profile No.	23/24.000	25.000	26.000	27.000
Part No.	23/24.Z08	25.Z08	26.Z08	27.Z08
B (mm)	50	50	80	80
H (mm)	70	70	100	100
L (mm)	200	200	280	300
D (mm)	17	21	21	31
e (mm)	15	15	18	20
d (mm)	11	11	21	21
l (mm)	150	150	220	240

Set of special nuts for sway bracing

.Z12

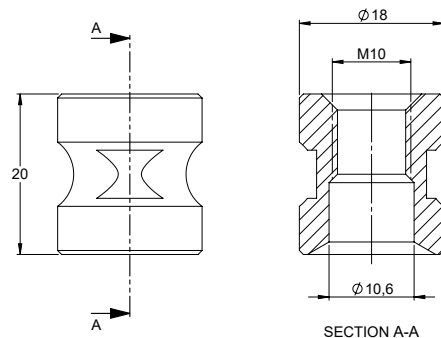
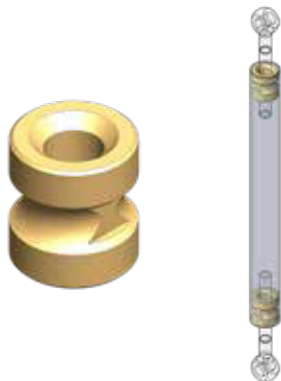

Adjustable joist clamp with support bracket (Parallel and 90° to the I-beam)

.B35/.B36

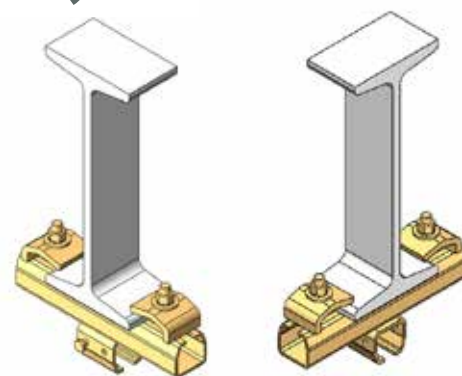
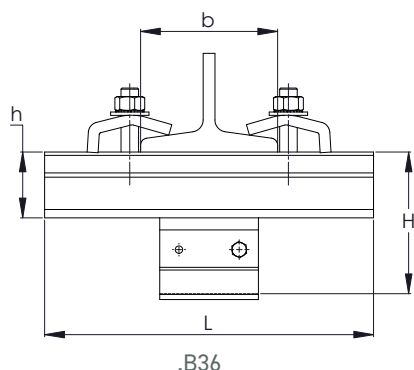

.B36
90° to the I-beam

.B35
Parallel to the I-beam

NIKO Profile No.	23.000	24.000	25.000	26.000	27.000
Part No.	23.B35	24.B35	25.B35	26.B35	27.B35
Part No.	23.B36	24.B36	25.B36	26.B36	27.B36
H (mm)	85	94	129	146	199
L (mm)	250	250	300	300	330
b max (mm)	150	150	175	175	205
h (mm)	43,5	43,5	60	60	75

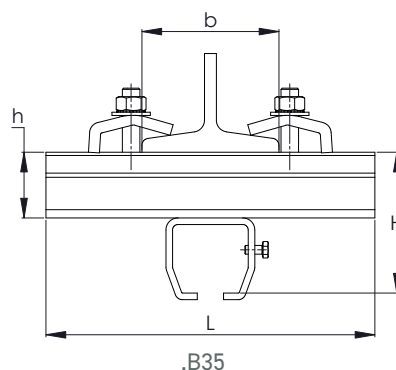

.B35

Adjustable joist clamp with splice joint (Parallel and 90° to the I-beam)

.B71/.B72

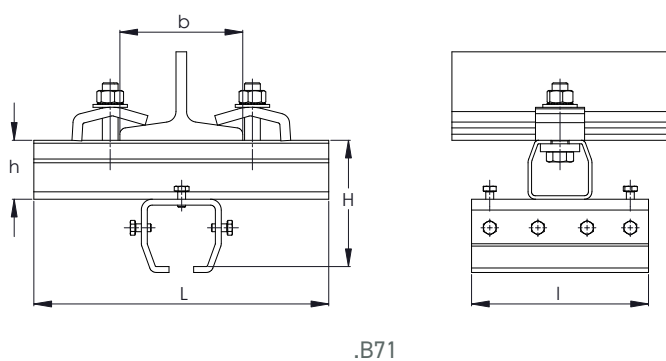

.B71

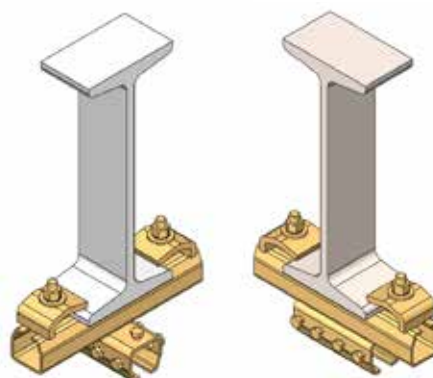

.B71
Parallel to the I-beam

.B72
90° to the I-beam

NIKO Profile No.	23.000	24.000	25.000	26.000	27.000
Part No.	23.B71	24.B71	25.B71	26.B71	27.B71
Part No.	23.B72	24.B72	25.B72	26.B72	27.B72
H (mm)	85	94	129	146	199
h (mm)	43,5	43,5	60	60	75
l (mm)	120	150	180	200	250
L (mm)	250	250	300	300	330
b max (mm)	150	150	175	175	205

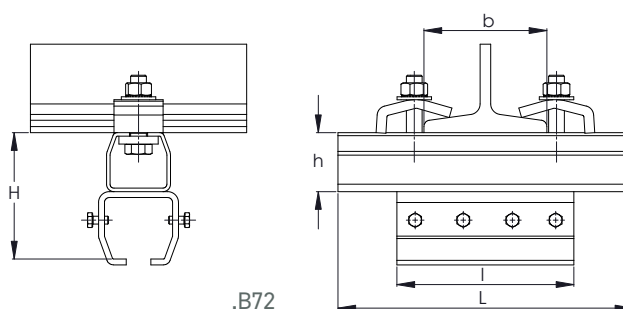

.B72

Conveyor Systems

We reserve the right for technical amendments without obligation.
The product pictures and drawings depicted in this catalogue do not always reflect all available sizes.

.B55
parallel to the I-beam

.B56
vertical to the I-beam

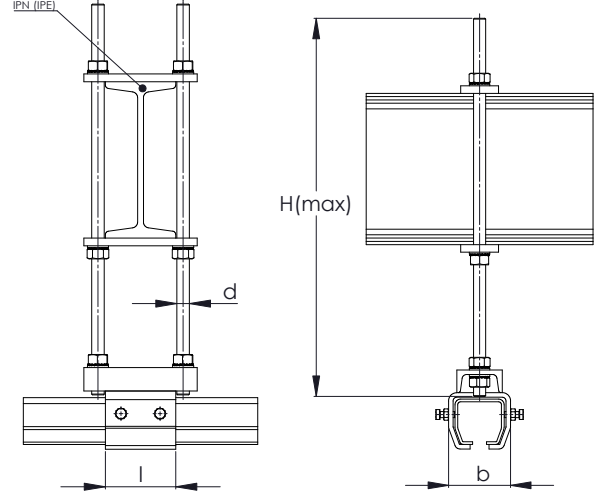
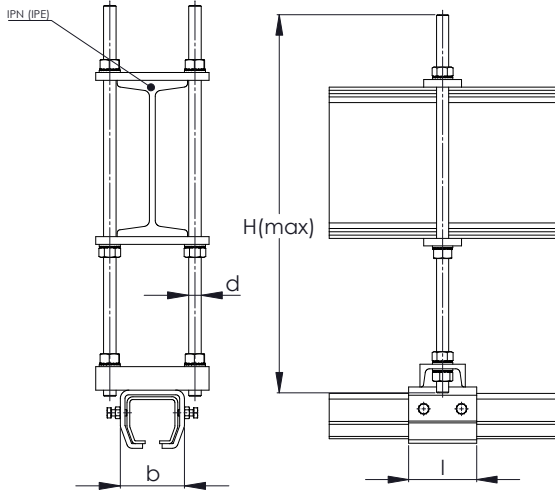

.B55

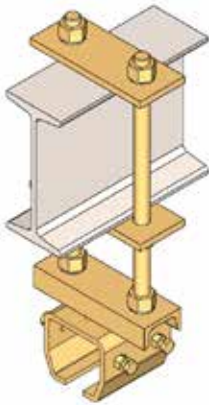

.B56

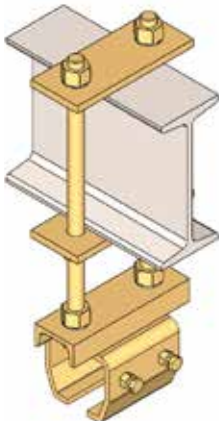

NIKO Profile No.	23.000	24.000	25.000	26.000	27.000
Bracket No. for IPN 80 (IPE 80)	23.B55.080	24.B55.080			
	23.B56.080	24.B56.080			
Bracket No. for IPN 100 (IPE 80)	23.B55.100	24.B55.100	25.B55.100		
	23.B56.100	24.B56.100	25.B56.100		
Bracket No. for IPN 120 (IPE 100)	23.B55.120	24.B55.120	25.B55.120		
	23.B56.120	24.B56.120	25.B56.120		
Bracket No. for IPN 140 (IPE 120)	23.B55.140	24.B55.140	25.B55.140		
	23.B56.140	24.B56.140	25.B56.140		
Bracket No. for IPN 160 (IPE 140)		24.B55.160	25.B55.160	26.B55.160	
		24.B56.160	25.B56.160	26.B56.160	
Bracket No. for IPN 180 (IPE 160)		24.B55.180	25.B55.180	26.B55.180	
		24.B56.180	25.B56.180	26.B56.180	
Bracket No. for IPN 200 (IPE 180)		24.B55.200	25.B55.200	26.B55.200	27.B55.200
		24.B56.200	25.B56.200	26.B56.200	27.B56.200
Bracket No. for IPN 220 (IPE 200)			25.B55.220	26.B55.220	27.B55.220
			25.B56.220	26.B56.220	27.B56.220
Bracket No. for IPN 240 (IPE 220)			25.B55.240	26.B55.240	27.B55.240
			25.B56.240	26.B56.240	27.B56.240
Bracket No. for IPN 260 (IPE 240)			25.B55.260	26.B55.260	27.B55.260
			25.B56.260	26.B56.260	27.B56.260
b (mm)	50	61	81	100	116
l (mm)	56	68	90	110	120
H max (mm)	500	500	500	500	500
d (mm)	M12	M16	M16	M20	M20

Scaffolding Splice Joint

.B80

NIKO Profile No.	24.000	25.000	26.000	27.000
Part No.	24.B80	25.B80	26.B80	27.B80
L (mm)	150	180	200	250
b (mm)	61	81	100	116
h (mm)	54	75	94	133
s (mm)	4,5	6	8	10

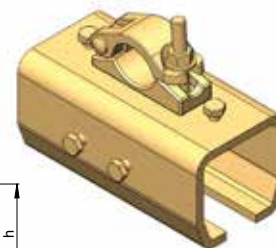
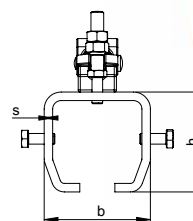
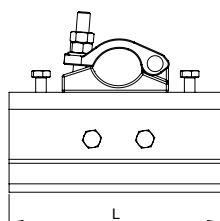

Scaffolding Support Bracket

.B81

NIKO Profile No.	24.000	25.000	26.000	27.000
Part No.	24.B81	25.B81	26.B81	27.B81
L (mm)	68	90	110	120
b (mm)	61	81	100	116
h (mm)	54	75	94	133
s (mm)	4,5	6	8	10

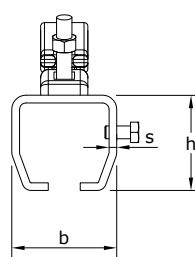
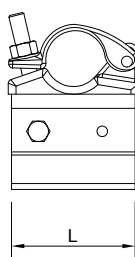

NIKO Bearings Options

NIKO-Profile

21. 23. 24. 25. 26. 27.

Low temperature bearings (special grease) for operating temperatures from -50°C to 80°C		TL.23	TL.24	TL.25	TL.26	TL.27	
High temperature bearings(special grease) for operating temperatures from -40°C to 260°C		TH.23	TH.24	TH.25	TH.26	TH.27	
Nylon tyred bearings	PL.21	PL.23	PL.24	PL.25			
Heavy duty polyamide tyred bearings		PLN.23	PLN.24	PLN.25	PLN.26	PLN.27	
Ammonia resistant bearings (special grease) for operating- temperatures from -20°C to 130°C	AM.21	AM.23	AM.24	AM.25	AM.26	AM.27	
Stainless steel bearings for operating temperatures from -20°C to 80°C	IN.21	IN.23	IN.24	IN.25			
Phosphor bronze tyred bearing		PB.23	PB.24	PB.25	PB.26	PB.27	

4-Wheel Trolley for Welding

.T00

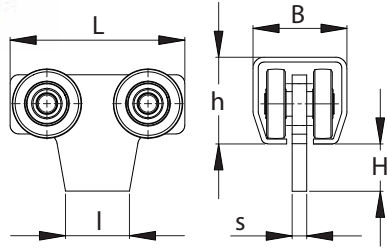
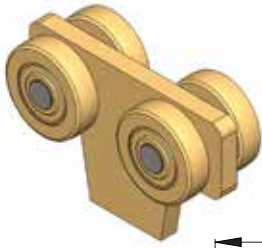

NIKO Profile No.	21.000	23.000	24.000	25.000	26.000	27.000
Part No.	21.T00	23.T00	24.T00	25.T00	26.T00	27.T00
SWL Kg	20	40	80	200	400	800
H (mm)	24	25	34	34	42,5	49
L (mm)	60	80	100	120	145	210
h (mm)	28	35	43,5	60	75	110
b (mm)	30	40	48,5	65	80	90
L1 (mm)	19	30	35	45	83	105
s (mm)	4,5	6	8	10	12	15

2-Wheel Trolley for Welding

.T01

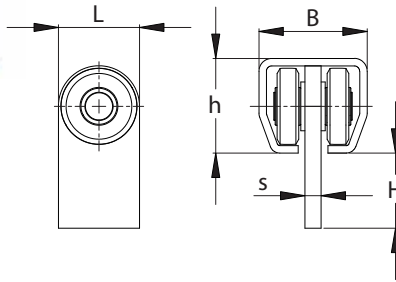

NIKO Profile No.	21.000	23.000	24.000	25.000	26.000	27.000
Part No.	21.T01	23.T01	24.T01	25.T01	26.T01	27.T01
SWL Kg	10	20	40	100	200	400
H (mm)	24	25	34	34	42,5	49
h (mm)	28	35	43,5	60	75	110
B (mm)	30	40	48,5	65	80	90
L (mm)	25	30	40	50	70	100
s (mm)	5	6	8	10	12	15

4-Wheel Trolley with Hole

.T10

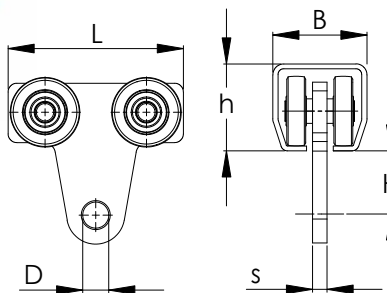
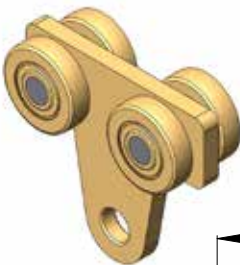

NIKO Profile No.	21.000	23.000	24.000	25.000	26.000	27.000
Part No.	21.T10	23.T10	24.T10	25.T10	26.T10	27.T10
SWL Kg	20	40	80	200	400	800
B (mm)	30	40	48,5	65	80	90
H (mm)	20,5	32	40	42	47	74
L (mm)	60	80	100	120	145	210
D (mm)	8	10	14	18	22	26
h (mm)	28	35	43,5	60	75	110
s (mm)	4,5	6	8	10	12	15

2-Wheel Trolley with Hole

.T11

NIKO Profile No.	21.000	23.000	24.000	25.000	26.000	27.000
Part No.	21.T11	23.T11	24.T11	25.T11	26.T11	27.T11
SWL Kg	10	20	40	100	200	400
B (mm)	30	40	48,5	65	80	90
H (mm)	20	32	39	42	47	73
L (mm)	25	30	40	50	70	100
D (mm)	6	10	14	18	22	26
h (mm)	28	35	43,5	60	75	110
s (mm)	5	6	8	10	12	15

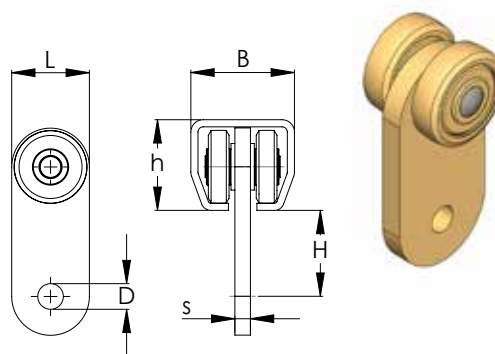

Trolleys for Chain

.T05/.T06

Our 2 or 4 wheel trolleys for power chain driven systems are suitable for hanging loads, for production lines which are electrically operated and for transporting products.

NIKO Profile No.	23.000		24.000		25.000
Part No.	23.T05	23.T06	24.T05	24.T06	25.T06
SWL Kg	20	40	40	80	200
L (mm)	40	80	40	100	120
b (mm)	40		48,5		65
h (mm)	35		43,5		60
h1 (mm)	40		49		49,5
h2 (mm)	80		89,5		89,5
e (mm)	10		10		10
d (mm)	8,2		8,2		8,2

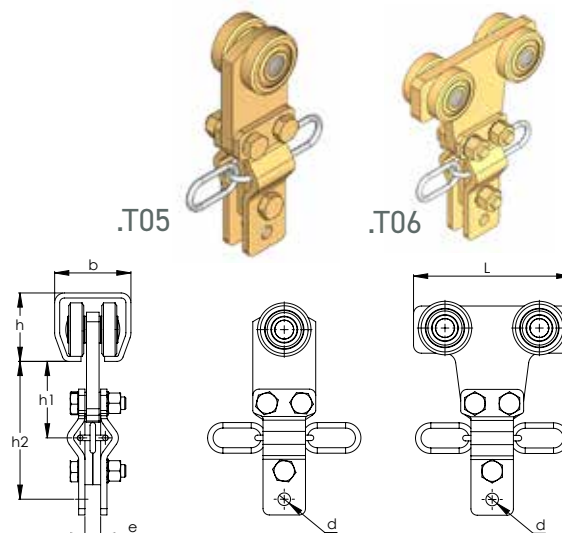

4-Wheel Trolley with two Holes

.T07

NIKO Profile No.	23.000	24.000	25.000
Part No.	23.T07	24.T07	25.T07
SWL Kg	40	80	200
H (mm)	18,5	27	29
h (mm)	35	43,5	60
b (mm)	40	48,5	65
L (mm)	80	100	120
d (mm)	8	8	9
S (mm)	6	8	10
l (mm)	21,5	21,5	21

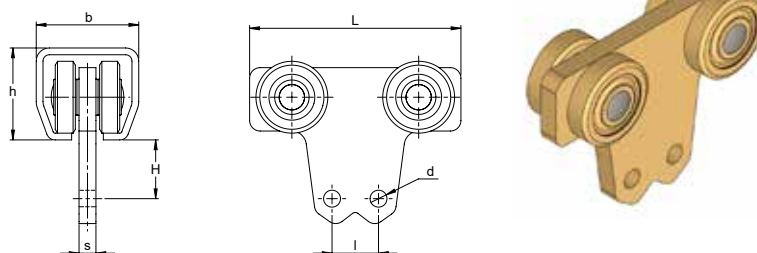

2-Wheel Trolley with two Holes

.T08

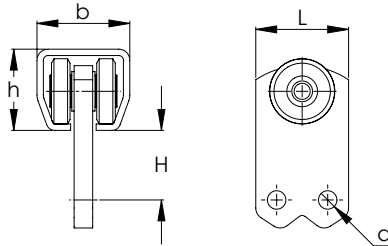

NIKO Profile No.	23.000	24.000
Part No.	23.T08	24.T08
SWL Kg	20	40
H (mm)	18	27
h (mm)	35	43,5
b (mm)	40	48,5
L (mm)	40	40
d (mm)	8	8

4-Wheel Trolley with Rotating Ring

.T70

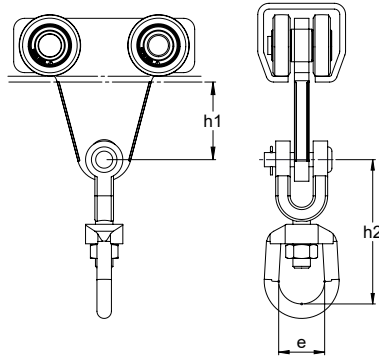

NIKO Profile No.	23.000	24.000	25.000	26.000	27.000
Part No.	23.T70	24.T70	25.T70	26.T70	27.T70
SWL Kg	40	80	200	400	800
h1 (mm)	32	39	42	46	73
h2 (mm)	79	79	79	98	126
e (mm)	25	25	25	31	37

4-Wheel Trolley with Rotating Hook

.T71

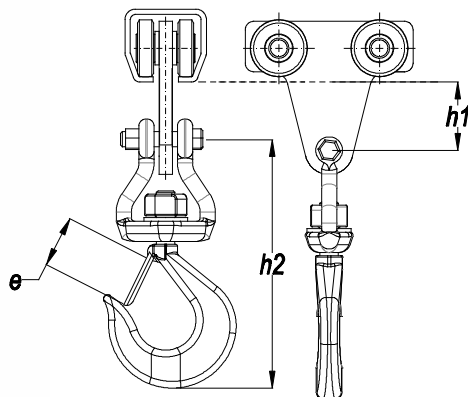

NIKO Profile No.	24.000	25.000	26.000	27.000
Part No.	24.T71	25.T71	26.T71	27.T71
SWL Kg	80	200	400	800
h1 (mm)	42	46	73	73
h2 (mm)	125	125	152	126
e (mm)	24	24	28	37

4-Wheel Trolley with Rotating Screw

.T14

With a special ball joint in order for the screw to rotate and oscillate 15°.

NIKO Profile No.	23.000	24.000	25.000	26.000	27.000
Part No.	23.T14	24.T14	25.T14	26.T14	27.T14
SWL Kg	40	80	200	400	800
H max (mm)	68	79	107	134	153
H min (mm)	62	70	96	118	123
h (mm)	35	43,5	60	75	110
b (mm)	40	48,5	65	80	90
L (mm)	70	90	110	140	200
d (mm)	M12	M16	M20	M24	M30

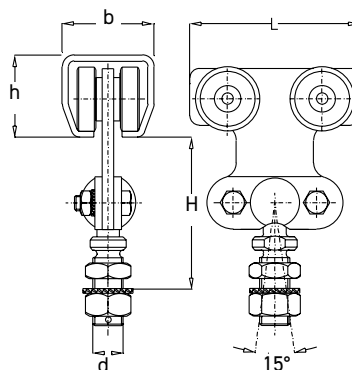

4-wheel trolley with rotating screw and guide rollers

.T114

Profil Nr.	25.000	26.000
Part No.	25.T114	26.T114
SWL Kg	200	400
d (mm)	107	134
d1 (mm)	96	118
L (mm)	60	75
h (mm)	75	80
b (mm)	107	142
H (mm)	20	24

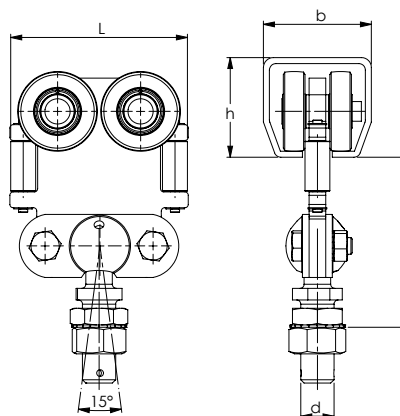

2-Wheel Trolley with Rotating Screw

.T15

With a special ball joint in order for the screw to rotate and oscillate 15°.

NIKO Profile No.	23.000	24.000	25.000	26.000	27.000
Part No.	23.T15	24.T15	25.T15	26.T15	27.T15
SWL Kg	20	40	100	200	400
H max (mm)	68	79	107	134	153
H min (mm)	62	70	96	118	123
h (mm)	35	43,5	60	75	110
b (mm)	40	48,5	65	80	90
d (mm)	M12	M16	M20	M24	M30
L (mm)	66	72	96	122	122

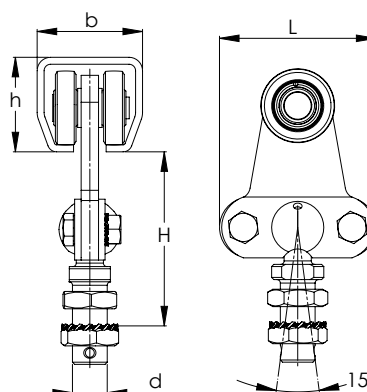

4-Wheel Trolley with a Rotating Eye Nut DIN 582

.T20

With a ball joint in order for the ring to rotate and oscillate.

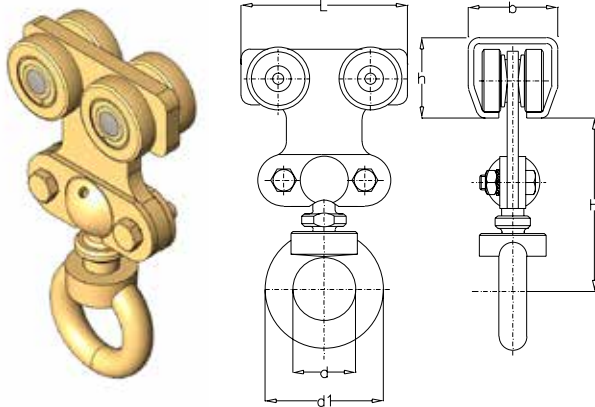

NIKO Profile No.	23.000	24.000	25.000	26.000	27.000
Part No.	23.T20	24.T20	25.T20	26.T20	27.T20
SWL Kg	40	80	200	400	800
H (mm)	85	96,5	122	145	182
h (mm)	35	43,5	60	75	110
b (mm)	40	48,5	65	80	90
L (mm)	70	90	110	140	200
d (mm)	30	35	40	50	60
d1 (mm)	54	63	72	90	108

2-Wheel Trolley with a Rotating Eye Nut DIN 582

.T19

With a ball joint in order for the ring to rotate and oscillate.

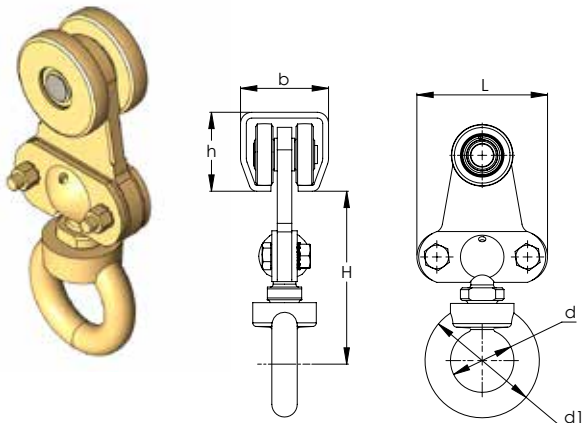

NIKO Profile No.	23.000	24.000	25.000	26.000	27.000
Part No.	23.T19	24.T19	25.T19	26.T19	27.T19
SWL Kg	20	40	100	200	400
H (mm)	85	96,5	122	145	182
h (mm)	35	43,5	60	75	110
b (mm)	40	48,5	65	80	90
L (mm)	66	72	96	122	122
d (mm)	30	35	40	50	60
d1 (mm)	54	63	72	90	108

4-Wheel Trolley with Rotating Screw

.T12

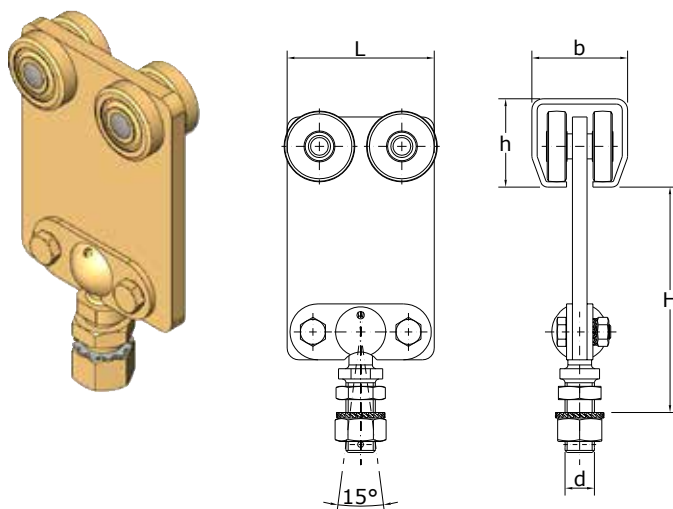

NIKO Profile No.	24.000	25.000	26.000	27.000
Part No.	24.T12	25.T12	26.T12	27.T12
SWL Kg	80	200	400	800
L (mm)	90	100	120	150
b (mm)	48,5	65	80	90
h (mm)	43,5	60	75	110
H (mm)	113	148	181	226
d (mm)	M16	M20	M24	M30

4-Wheel Trolley With a Rotating Eye Nut DIN 582

.T13

NIKO Profile No.	24.000	25.000	26.000	27.000
Part No.	24.T13	25.T13	26.T13	27.T13
SWL Kg	80	200	400	800
L (mm)	90	100	120	150
b (mm)	48,5	65	80	90
h (mm)	43,5	60	75	110
H (mm)	113	148	181	226
d (mm)	35	40	50	60
d ₁ (mm)	63	72	90	108

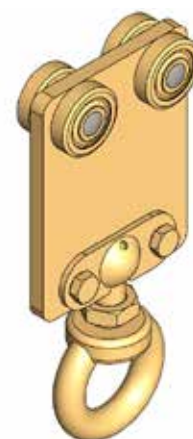
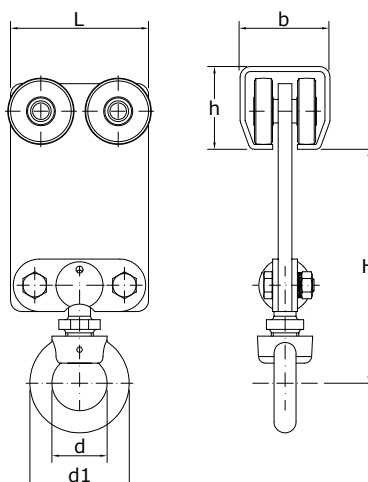

4-Wheel Trolley with Rotating Screw and Guide Rollers

.T42

NIKO Profile No.	24.000	25.000	26.000	27.000
Part No.	24.T42	25.T42	26.T42	27.T42
SWL Kg	80	200	400	800
L (mm)	90	100	140	180
b (mm)	48,5	65	80	90
h (mm)	43,5	60	75	110
H (mm)	113	148	181	226
d (mm)	M16	M20	M24	M30

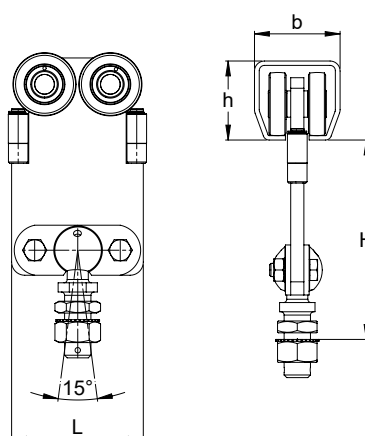

CONVEYOR SYSTEMS

4-Wheel Trolley with a Rotating Eye Nut DIN 582 and Guide Rollers

.T43

NIKO Profile No.	24.000	25.000	26.000	27.000
Part No.	24.T43	25.T43	26.T43	27.T43
SWL Kg	80	200	400	800
d (mm)	35	40	50	60
d ₁ (mm)	63	72	90	108
L (mm)	90	100	140	180
h (mm)	43,5	60	75	110
b (mm)	48,5	65	80	90
H (mm)	129	164	197	242

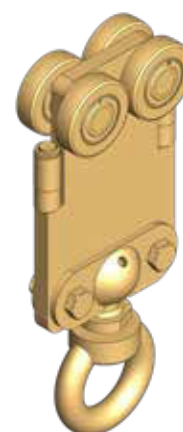
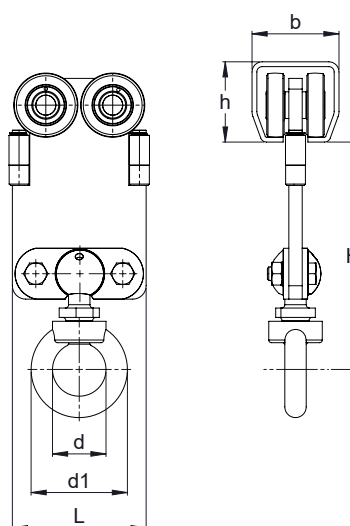

4-Wheel Trolley with a Rotating Eye Nut DIN 582

.T40

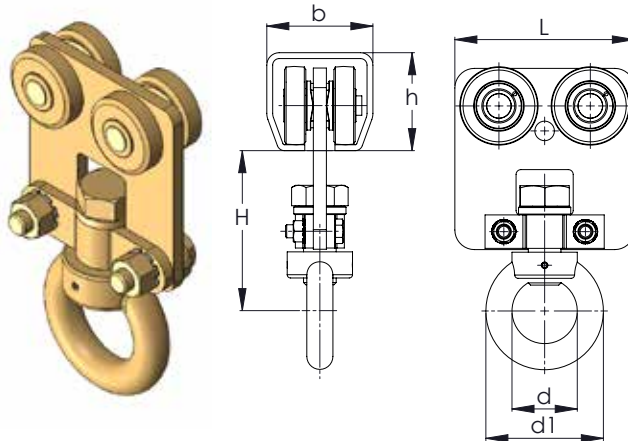

NIKO Profile No.	23.000	24.000	25.000	26.000	27.000
Part No.	23.T40	24.T40	25.T40	26.T40	27.T40
Traglast (Kg)	40	80	200	400	800
b (mm)	40	48,5	65	80	90
H (mm)	74	82	98	126	165
L (mm)	68	90	110	150	200
d1 (mm)	54	63	72	90	108
h (mm)	35	43,5	60	75	110
d (mm)	30	35	40	50	60

4-Wheel Trolley without a Rotating Eyenut

.T41

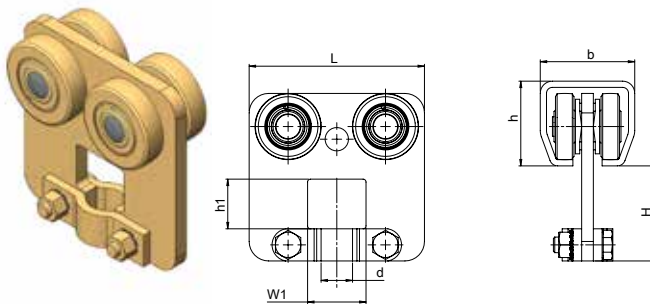

NIKO Profile No.	23.000	24.000	25.000	26.000	27.000
Part No.	23.T41	24.T41	25.T41	26.T41	27.T41
SWL Kg	40	80	200	400	800
L (mm)	68	90	110	150	200
b (mm)	40	48,5	65	80	90
h (mm)	35	43,5	60	75	110
H (mm)	32	46,5	50	75	90
d (mm)	12	16	20	24	30
w1 (mm)	22,5	30	35	47,5	60
h1 (mm)	20	25,5	27,5	30	40

4-wheel trolley without a rotating eye, with guide rolles (M16&M20)

.T141

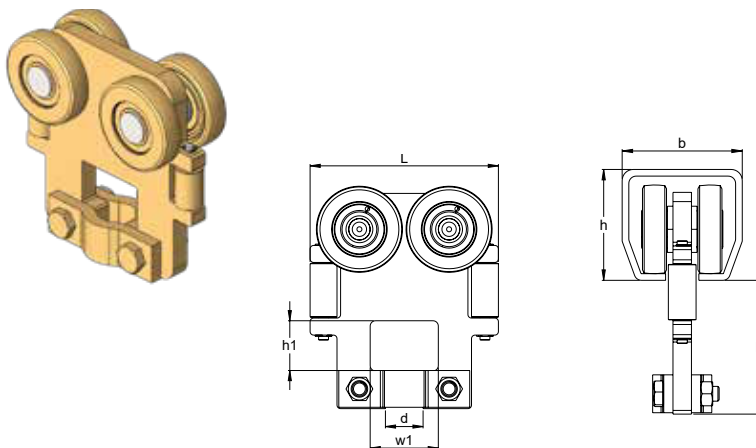

Profil Nr.	25.000	26.000
Part No.	25.T141	26.T141
SWL Kg	200	400
L (mm)	105	144
b (mm)	65	80
h (mm)	60	75
H (mm)	50	75
d (mm)	16	20
w1 (mm)	38	47,5
h1 (mm)	27,5	30

4-wheel trolley without a rotating eye, with guide rolles (M20&M24)

.T241

Profil Nr.	25.000	26.000
Part No.	25.T241	26.T241
SWL Kg	200	400
L (mm)	105	144
b (mm)	65	80
h (mm)	60	75
H (mm)	50	75
d (mm)	20	24
w1 (mm)	38	47.5
h1 (mm)	27,5	30

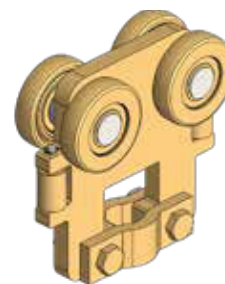
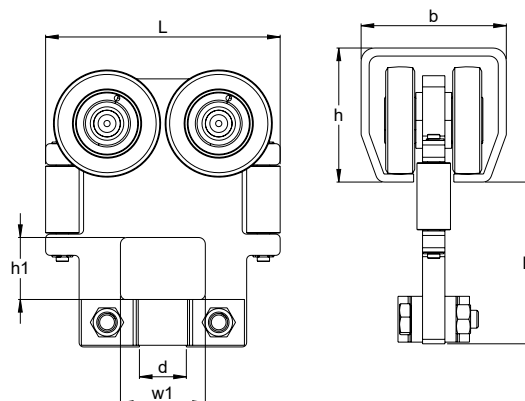

4-Wheel Trolley with Rotating Screw

.R51

NIKO Profile No.	23.000	24.000	25.000	26.000	27.000
Part No.	23.R51	24.R51	25.R51	26.R51	27.R51
SWL Kg	40	80	200	400	800
L (mm)	68	90	110	150	200
H (mm)	120	140	187	285	360
s (mm)	4,5	6	8	12	15
d1 (mm)	28	34	48	60	89
h (mm)	45	49	61	78	109
d (mm)	M12	M16	M20	M24	M30

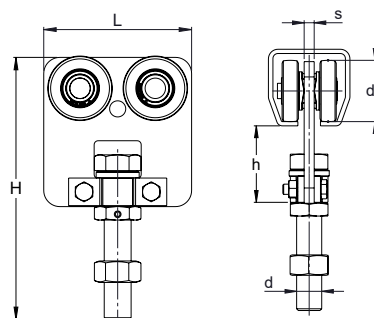

4-Wheel Trolley with Pin and Buffer (plate)

.T48

This 4-wheel trolley is recommended for use only in straight sections.
Not to be used in switches or bends.

NIKO Profile No.	24.000	25.000	26.000	27.000
Part No.	24.T48	25.T48	26.T48	27.T48
SWL Kg	125	250	500	1000
L (mm)	100	130	152	215
H (mm)	65	77	94	123
b (mm)	48,5	65	80	90
h (mm)	43,5	60	75	110
d (mm)	16	20	22	26
c (mm)	30	37	37	45

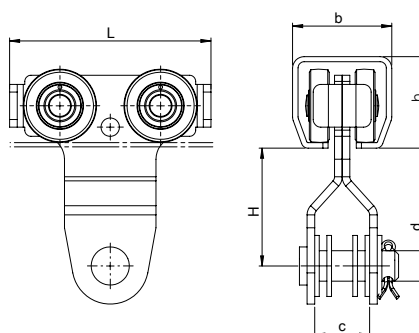

4-Wheel Trolley with Rotating Screw, "Dog Pin" and Guide Rollers

.T47

These 4-wheel trolley are most commonly used for power chain driven systems.

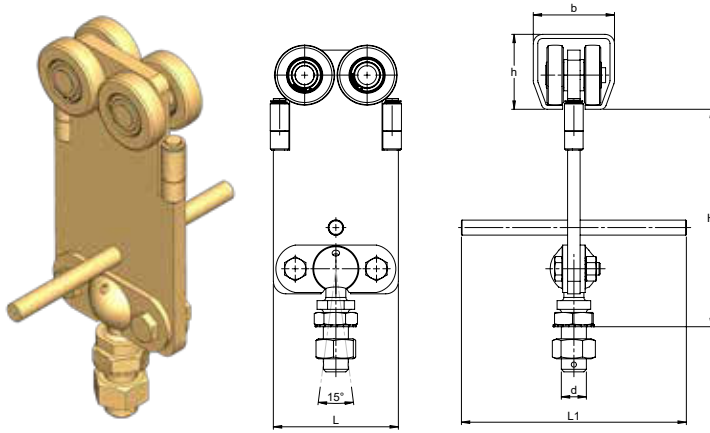

NIKO Profile No.	24.000	25.000	26.000	27.000
Part No.	24.T47	25.T47	26.T47	27.T47
SWL Kg	80	200	400	800
L (mm)	90	100	126	120
h (mm)	43,5	60	74	110
b (mm)	48,5	65	80	90
L1 (mm)	160	180	220	280
d (mm)	M16	M20	M24	M30
H (mm)	148	182	245	265

Trolley with Spring loaded 90° Rotating Indexing Unit

.T30/.T31

CONVEYOR SYSTEMS

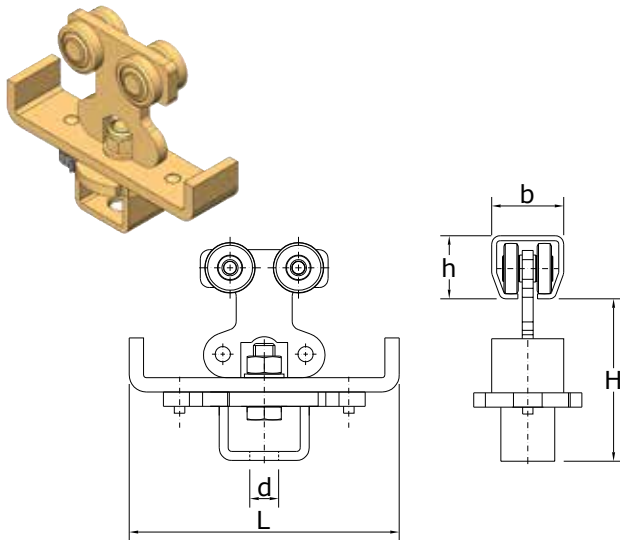

NIKO Profile No.	23.000		24.000		25.000	
Part No.	23.T30	23.T31	24.T30	24.T31	25.T30	25.T31
SWL Kg	40	40	80	80	160	160
L (mm)	150	250	150	250	150	250
H (mm)	88	88	97	97	117,5	117,5
h (mm)	35	35	43,5	43,5	60	60
b (mm)	40	40	48,5	48,5	65	65
d (mm)	16	16	16	16	16	16

90° Rotating Indexing Unit (spring type)

.T75/.T76

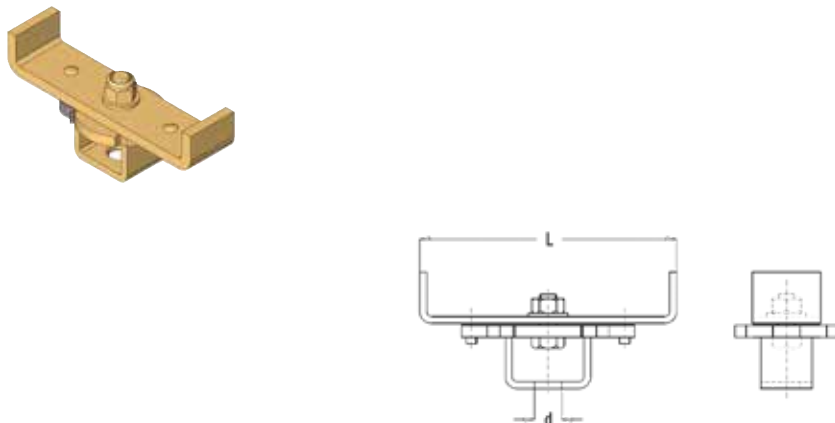

NIKO Profile No.	24.000	
Part No.	24.T75	24.T76
L (mm)	150	250
d (mm)	16	16

Trolley with Stainless Steel Hook

.T21/.T22

Suitable for the transport of meat with a rotation capability of 360° and swinging at a 15° angle.

NIKO Profile No.	24.000		25.000	
Part No.	24.T22	24.T21	25.T22	25.T21
SWL Kg	100	100	200	200
H (mm)	243	253	280	270
h (mm)	43,5	43,5	60	60
b (mm)	48,5	48,5	65	65
L (mm)	90	90	110	110
d (mm)	16	14	16	16

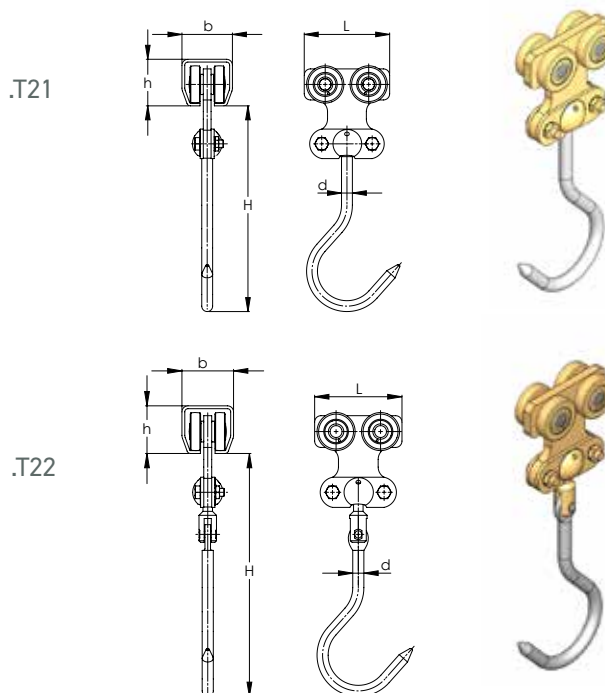

General technical notes

- For better operational efficiency in conveyor systems with bends and switches, NIKO recommends the usage of 4-wheel trolleys.
- Trolleys with rotating screw (e.g. .T14) are recommended for conveyor systems with bends and switches.
- Trolleys with rotating screw (e.g. .T14) are recommended for the assembly of flight bars.

Flight Bar with Fixed Eye Nut

.T24

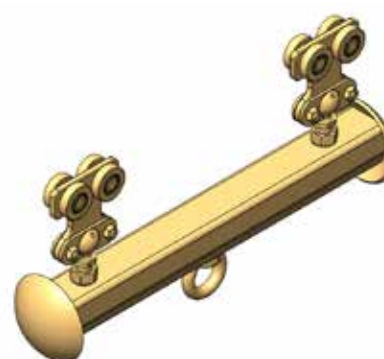
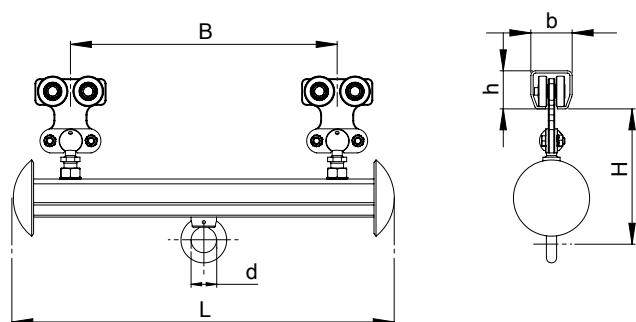

NIKO Profile No.	23.000	24.000	25.000	26.000	27.000
Part No.	23.T24	24.T24	25.T24	26.T24	27.T24
SWL Kg	80	160	400	800	1600
H (mm)	128	152	190	250	310
h (mm)	35	43,5	60	75	110
b (mm)	40	48,5	65	80	90
B (mm)	180	300	420	500	700
L (mm)	300	450	600	700	1000
d (mm)	30	35	40	50	60

Flight Bar with Rotating Eye Nut

.T26

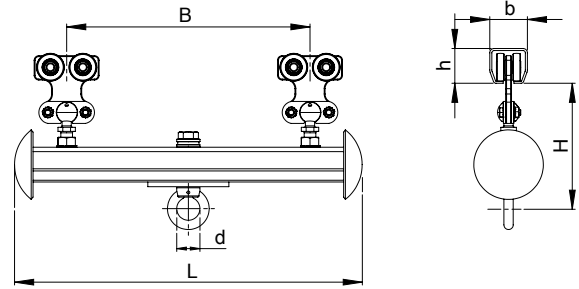
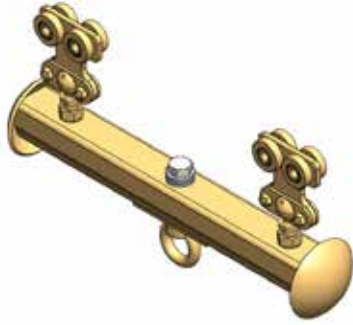

NIKO Profile No.	23.000	24.000	25.000	26.000	27.000
Part No.	23.T26	24.T26	25.T26	26.T26	27.T26
SWL Kg	80	160	400	800	1600
H (mm)	133	160	200	260	320
h (mm)	35	43,5	60	75	110
b (mm)	40	48,5	65	80	90
B (mm)	180	300	420	500	700
L (mm)	300	450	600	700	1000
d (mm)	30	35	40	50	60

Flight Bar with Fixed Hook

.T28

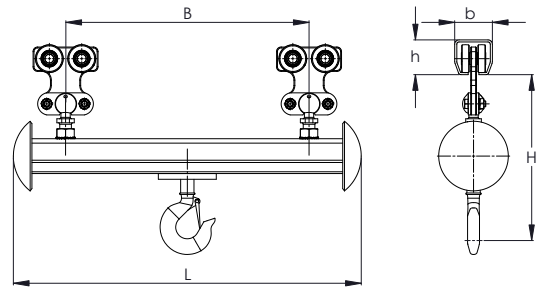
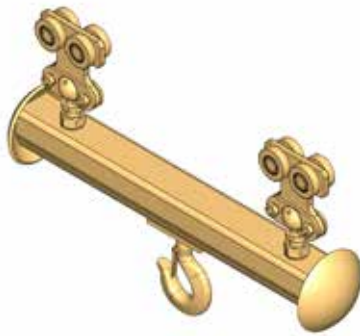

NIKO Profile No.	23.000	24.000	25.000	26.000	27.000
Part No.	23.T28	24.T28	25.T28	26.T28	27.T28
SWL Kg	80	160	400	800	1600
H (mm)	200	230	280	330	410
h (mm)	35	43,5	60	75	110
b (mm)	40	48,5	65	80	90
B (mm)	180	300	420	500	700
L (mm)	300	450	600	700	1000

Flight Bar with Rotating Hook

.T38

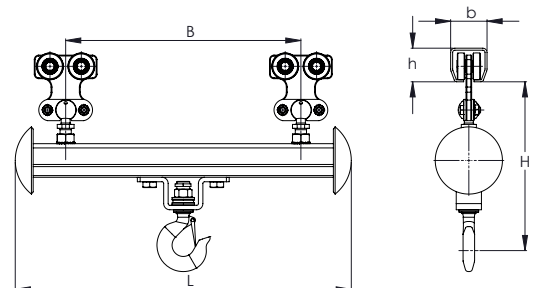
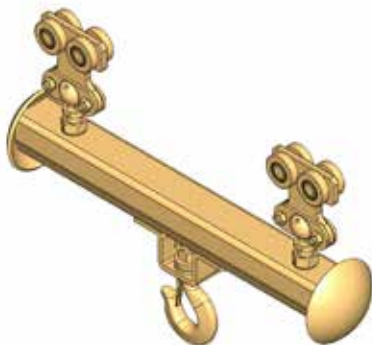

NIKO Profile No.	23.000	24.000	25.000	26.000	27.000
Part No.	23.T38	24.T38	25.T38	26.T38	27.T38
SWL Kg	80	160	400	800	1600
H (mm)	205	235	290	330	415
h (mm)	35	43,5	60	75	110
b (mm)	40	48,5	65	80	90
B (mm)	180	300	420	500	700
L (mm)	300	450	600	700	1000

CONVEYOR SYSTEMS

Flight Bar with Spring Loaded 90° Rotating Indexing Unit (2 x .T14 trolley)

.T32

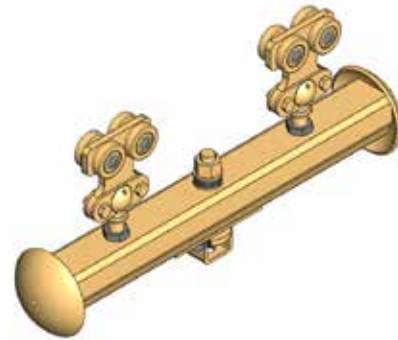
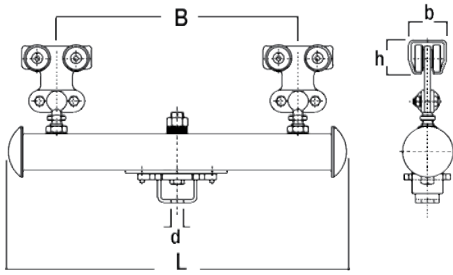

NIKO Profile No.	23.000	24.000	25.000
Part No.	23.T32	24.T32	25.T32
SWL Kg	80	160	160
B (mm)	180	300	420
L (mm)	300	450	500
h (mm)	35	43,5	60
b (mm)	40	48,5	65
d (mm)	16	16	16

Flight bar with Eye Nut

.T64/.T65

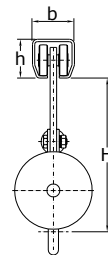
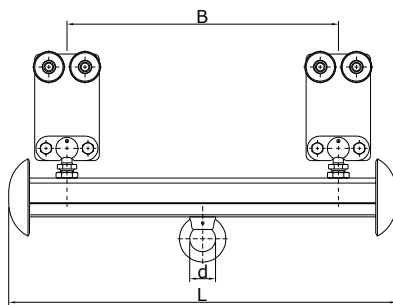

.T64 (2 x.T12 trolley)

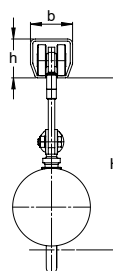
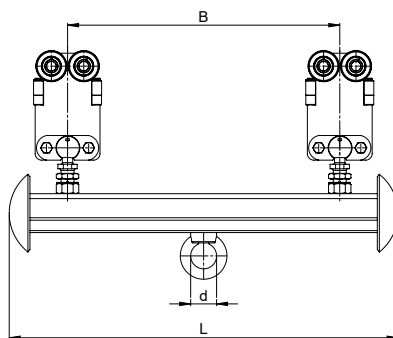
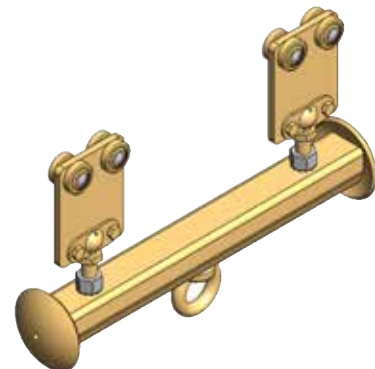

.T65 (2 x.T42 trolley)

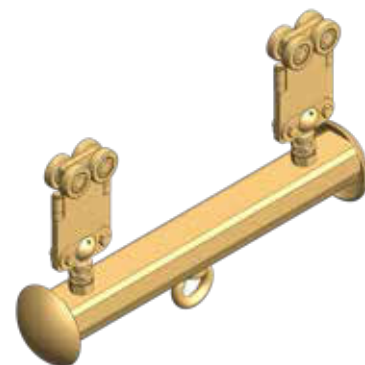

NIKO Profile No.	24.000	25.000	26.000	27.000
Part No.	24.T64	25.T64	26.T64	27.T64
Part No.	24.T65	25.T65	26.T65	27.T65
SWL Kg	160	400	800	1600
B (mm)	300	420	500	700
d (mm)	35	40	50	60
L (mm)	450	600	700	1000
h (mm)	43,5	60	75	110
b (mm)	48,5	65	80	90
H (mm)	190	243	300	390

Flight bar with Rotating Eye Nut

.T66/.T67

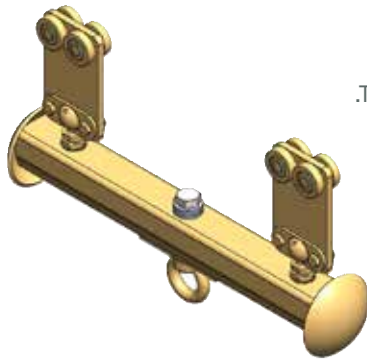

.T66 (2 x.T12 trolley)

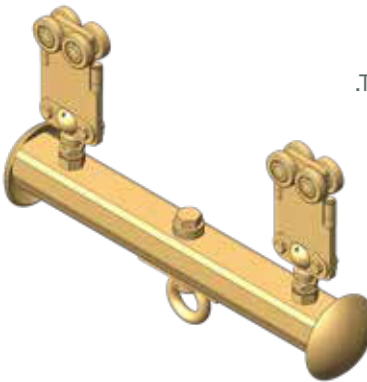

.T67 (2 x.T42 trolley)

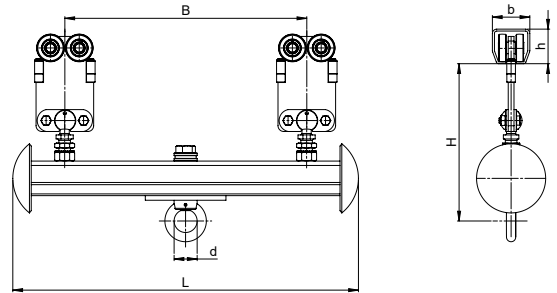
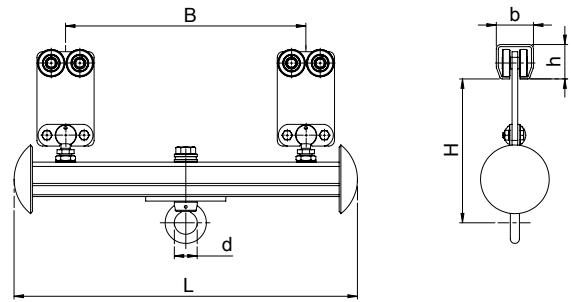

NIKO Profile No.	24.000	25.000	26.000	27.000
Part No.	24.T66	25.T66	26.T66	27.T66
Part No.	24.T67	25.T67	26.T67	27.T67
SWL Kg	160	400	800	1600
B (mm)	300	420	500	700
d (mm)	35	40	50	60
L (mm)	450	600	700	1000
h (mm)	43,5	60	75	110
b (mm)	48,5	65	80	90
H (mm)	198	251	310	400

CONVEYOR SYSTEMS

Flight bar with Eye Nut

.T101

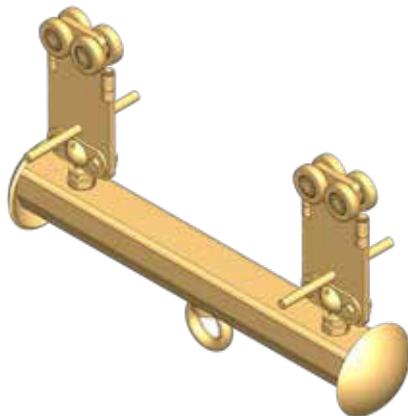

.T101 (2 x.T47 trolley)

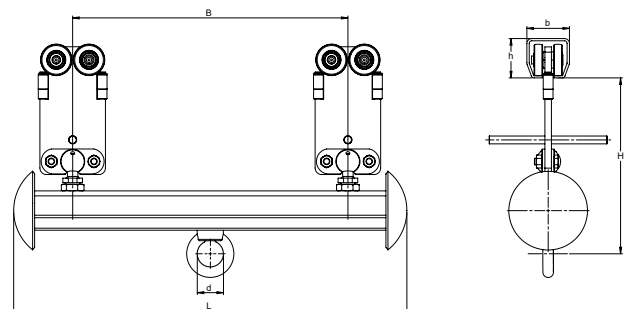

NIKO Profile No.	24.000	25.000	26.000	27.000
Part No.	24.T101	25.T101	26.T101	27.T101
h (mm)	43,5	60	75	110
b (mm)	48,5	65	80	90
B (mm)	300	420	500	700
L (mm)	450	600	700	1000
d (mm)	35	40	50	60
H (mm)	220	265	360	420

Flight bar with Rotating Eye Nut

.T103

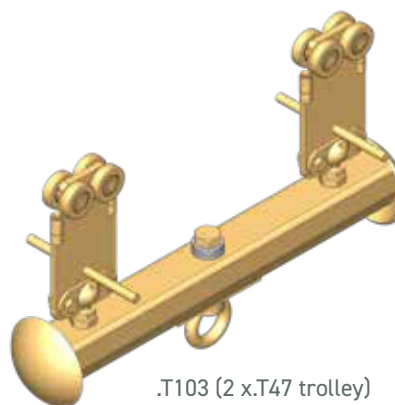
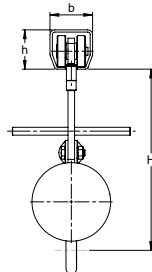
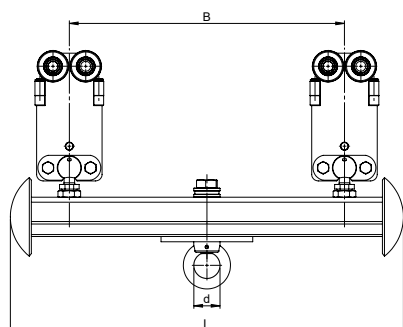

.T103 (2 x.T47 trolley)

NIKO Profile No.	24.000	25.000	26.000	27.000
Part No.	24.T103	25.T103	26.T103	27.T103
h (mm)	43,5	60	75	110
b (mm)	48,5	65	80	90
B (mm)	300	420	500	700
L (mm)	450	600	700	1000
d (mm)	35	40	50	60
H (mm)	228	275	370	430

* Flight bar type .101 & .103 with eye nut and rotating eye nut are most commonly used for power chain driven systems.

Heavy Duty Flight bar

.T69

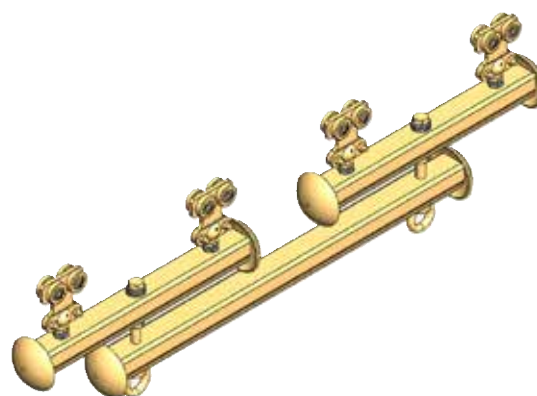

NIKO Profile No.	25.000	26.000	27.000
Part No.	25.T69	26.T69	27.T69
SWL Kg	800	1500	3000
B (mm)	420	500	700
L (mm)	800	1500	1600
l1 (mm)	1000	1860	2000
l2 (mm)	1400	2200	2600

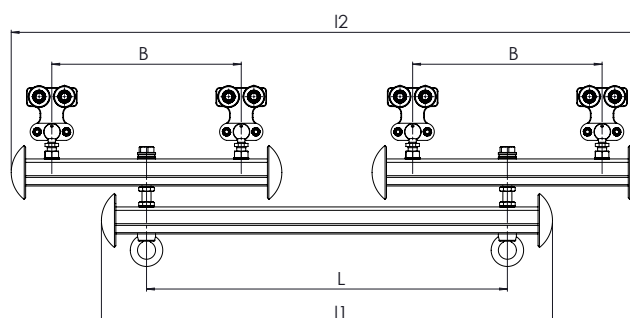

2-wheel trolley with rotating screw & guide roller bearings

.T142

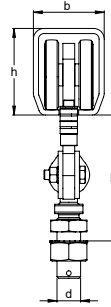
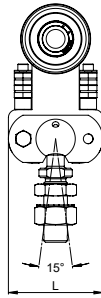

NIKO Profile No.	26.000	27.000
Part No.	26.T142	27.T142
SWL (kg)	200	400
H max (mm)	160	170
H min (mm)	140	140
h (mm)	75	110
b (mm)	80	90
L (mm)	120	120
d (mm)	24	30

Load carrier with 2pcs 2-wheel trolleys NR.27.T142 & screw

.T143

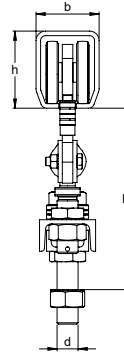
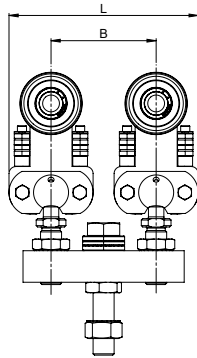
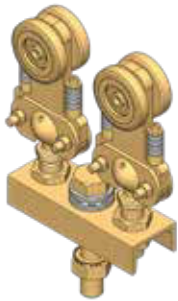

NIKO Profile No.	26.000	27.000
Part No.	26.T143	27.T143
SWL (kg)	400	800
H max (mm)	260	280
H min (mm)	210	220
h (mm)	75	110
b (mm)	80	90
L (mm)	260	270
d (mm)	24	30
B (mm)	140	150

Flight bar with 2pcs load carriers NR.27.T143, with screw

.T144

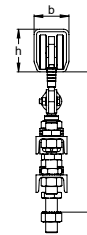
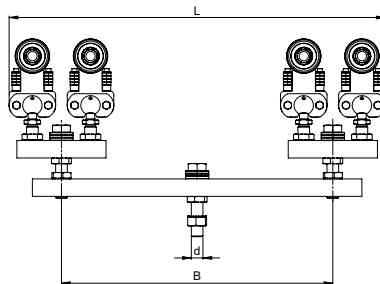
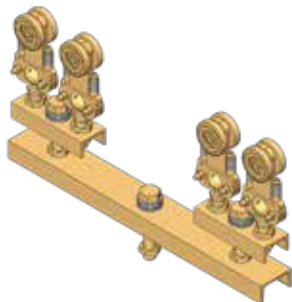

Profile No.	26.000	27.000
Part No.	26.T144	27.T144
SWL (kg)	800	1600
H max (mm)	350	380
H min (mm)	280	290
h (mm)	75	110
b (mm)	80	90
L (mm)	760	970
d (mm)	30	30
B (mm)	500	700

The use of 2-wheel trolleys .T142 is recommended for flight bars with loads exceeding 800Kg, in systems with bends and switches. The 2-wheel design with the guide roller bearings, improves flexibility and guidance, ensuring a better drive of the trolleys through the bends.

Telescopic drawing bar for flight bars

.T99

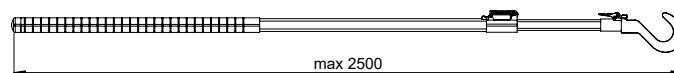
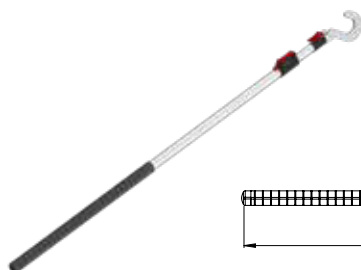

Profit Nr.	25.000
Art. Nr.	25.T99

Trolley with Double 90° Rotating Hanger

.T80

NIKO Profile No.	23.000	24.000
Part No.	23.T80	24.T80
SWL Kg	80	160
H (mm)	1200	1200
h (mm)	130	130
h1 (mm)	480	480
B (mm)	200	200
L (mm)	250	250
L1 (mm)	145	145

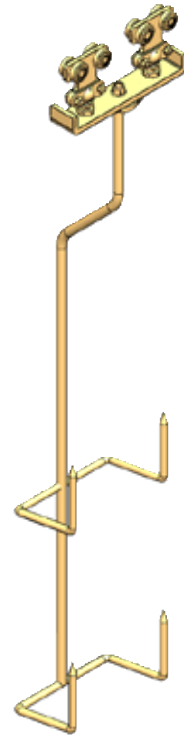
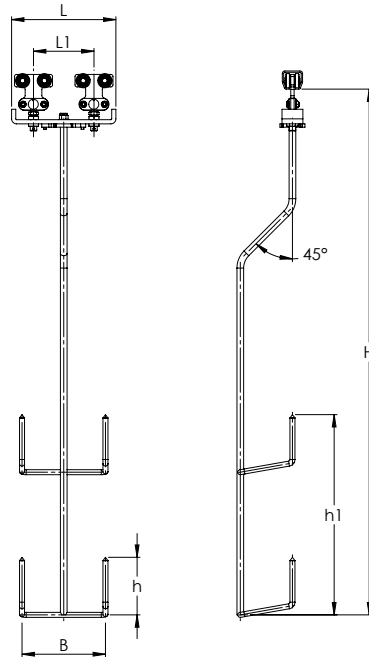

Trolley with Single 90° Rotating Hanger

.T82

NIKO Profile No.	23.000	24.000
Part No.	23.T82	24.T82
SWL Kg	80	160
H (mm)	1200	1200
h (mm)	130	130
B (mm)	200	200
L (mm)	250	250
L1 (mm)	145	145

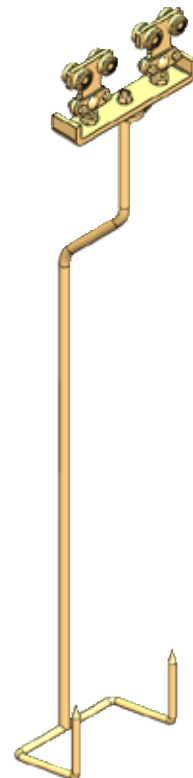
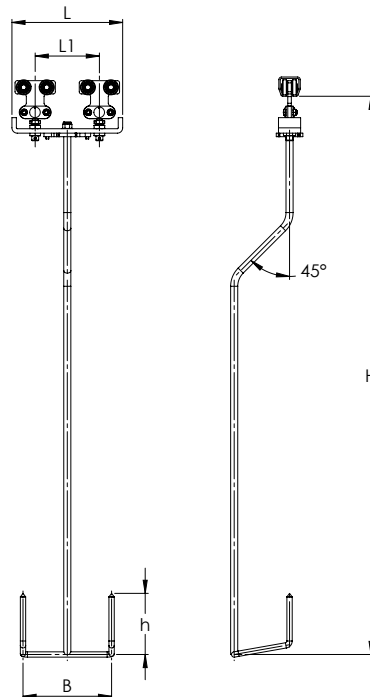

Single Tongue Switch complete with 60° Bend

.A02/.A03

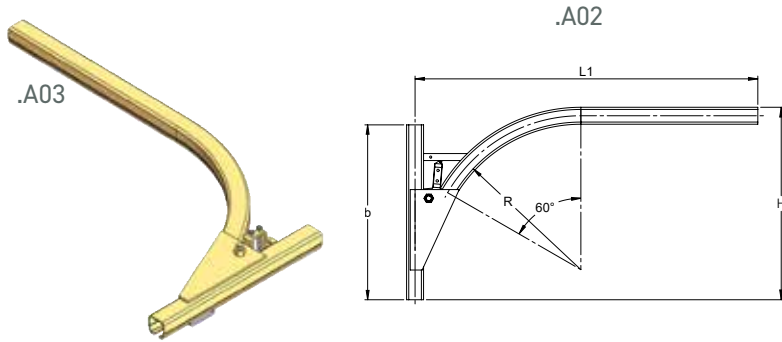

NIKO Profile No.	24.000	25.000	26.000
Right switch No.	24.A02	25.A02	26.A02
Left switch No.	24.A03	25.A03	26.A03
L1 (mm)	980	1350	1430
b (mm)	500	650	750
R (mm)	440	580	770
H (mm)	525	750	930

Tongue Switch without Bend & Automatic Single Tongue Switch Type C without bend

**.A04/.A05
.A12/.A13**

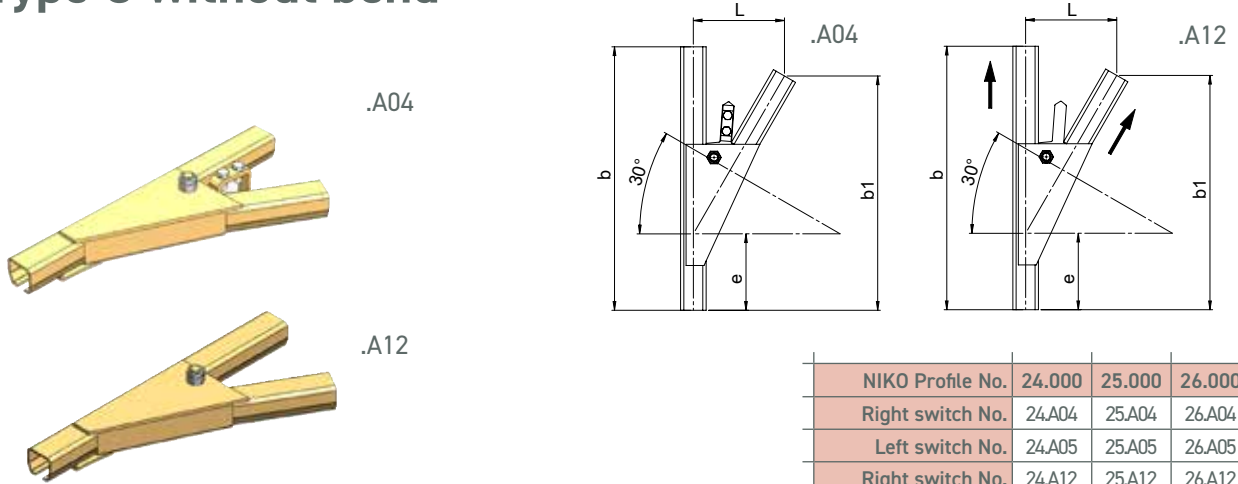

NIKO Profile No.	24.000	25.000	26.000
Right switch No.	24.A04	25.A04	26.A04
Left switch No.	24.A05	25.A05	26.A05
Right switch No.	24.A12	25.A12	26.A12
Left switch No.	24.A13	25.A13	26.A13
b (mm)	500	650	750
e (mm)	145	200	230
b1 (mm)	445	605	705
L (mm)	175	235	275

Triple Tongue Switch with Pneumatic Turntable

.A17/.A18

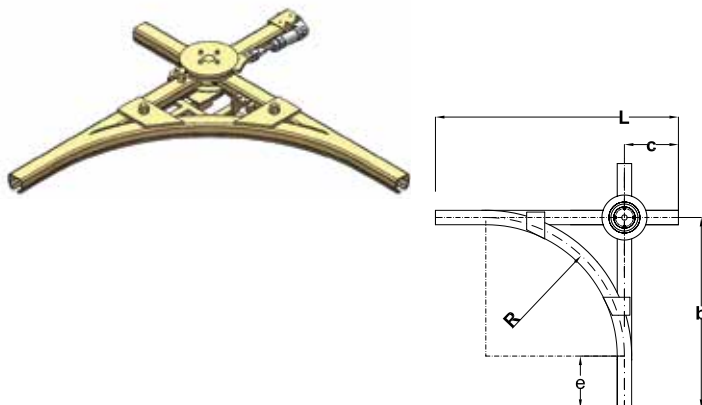

NIKO Profile No.	24.000	25.000	26.000	27.000*	
Part No.	24.A17	24.A18	25.A17	26.A17	27.A17
R (mm)	580	440	580	770	1035
b (mm)	700	590	760	1060	1285
L (mm)	950	840	1110	1460	1785
e (mm)	120	150	180	210	250
c (mm)	250	250	350	400	500

* Pneumatic cylinder is included

CONVEYOR SYSTEMS

Single Swivel Switch

.A38/.A39

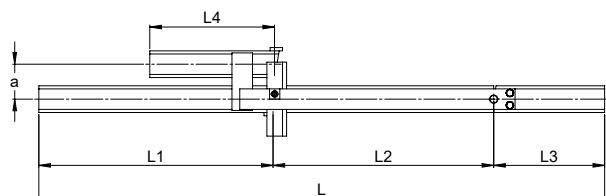

NIKO Profile No.	21.000	23.000	24.000	25.000	26.000	27.000
Right switch No.	21.A38	23.A38	24.A38	25.A38	26.A38	27.A38
Left switch No.	21.A39	23.A39	24.A39	25.A39	26.A39	27.A39
L1 (mm)	330	400	470	570	640	780
L2 (mm)	380	380	380	540	540	600
L3 (mm)	120	180	200	270	300	370
L4 (mm)	200	220	240	300	340	400
L (mm)	830	1180	1050	1380	1480	1750
a (mm)	40	55	63,5	85	100	115



With welded suspension plate and I-beam girder clamps, for supporting the switch from the main beam of the system support structure

Triple Swivel Switch

.A35

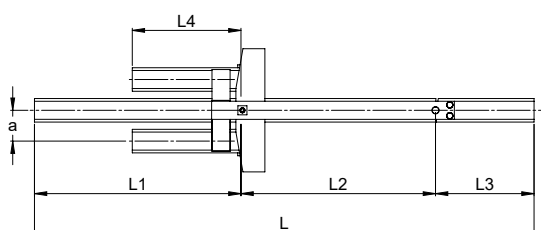

NIKO Profile No.	21.000	23.000	24.000	25.000	26.000	27.000
Part No.	21.A35	23.A35	24.A35	25.A35	26.A35	27.A35
L1 (mm)	330	400	470	570	640	780
L2 (mm)	380	380	380	540	540	600
L3 (mm)	120	180	200	270	300	370
L4 (mm)	200	220	240	300	340	400
L (mm)	830	1180	1050	1380	1480	1750
a (mm)	40	55	63,5	85	100	115



With welded suspension plate and I-beam girder clamps, for supporting the switch from the main beam of the system support structure

Trolley Input/Output Device

.A36/.A37

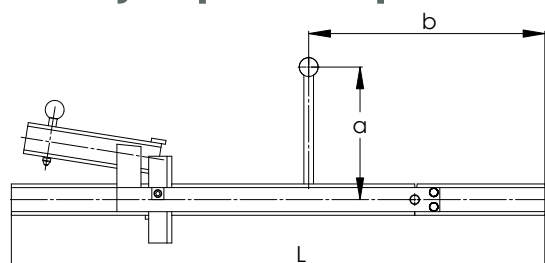

NIKO Profile No.	23.000	24.000	25.000	26.000	27.000
Right switch No.	23.A36	24.A36	25.A36	26.A36	27.A36
Left switch No.	23.A37	24.A37	25.A37	26.A37	27.A37
L (mm)	700	700	850	1000	1200
b (mm)	310	310	390	460	550
a (mm)	250	250	250	250	250

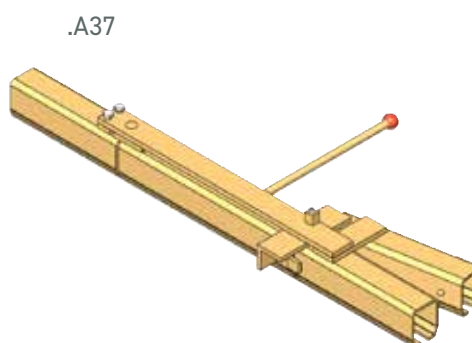

Switch Lever

SL.

Used to the change of direction of the track and in conveyor systems which are installed at a distance smaller than 2.5m from the ground.

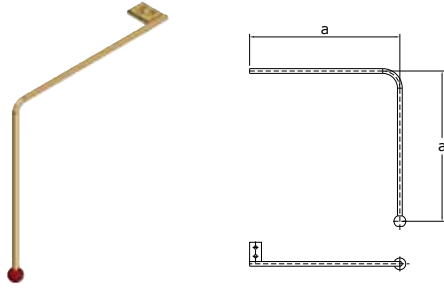

NIKO Profile No.	23.000	24.000	25.000	26.000
Part No.	SL23	SL24	SL25	SL26
a (mm)	500	500	500	500

Switch Double Pulling Chain

DL.

Used in conveyor systems at a distance of 2.5m or greater from the ground and where the installation of a switch lever may create problems.

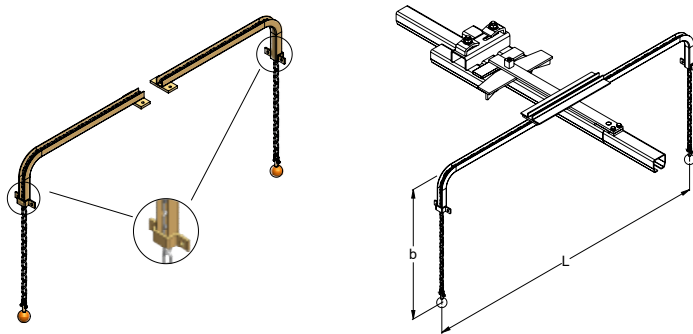

NIKO Profile No.	23.000	24.000	25.000	26.000
Part No.	DL23	DL24	DL25	DL26
L (mm)	1000	1000	1000	1000
b (mm)	500	500	500	500

Tongue Switch Pneumatic Operation (incl. cylinder) without Pneumatic Control

PN.

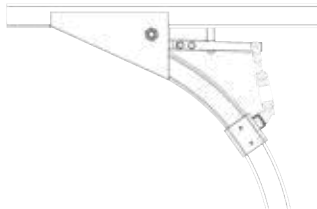

Tongue Switch Pneumatic Control (manual valve & 10m tube)

X7.003

Pneumatic control can be placed to every switch.



Air distributors/ manifolds

X7.023
3+1 ways

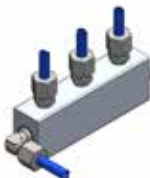

X7.024
4+1 ways



X7.025
5+1 ways



Single Tongue Switch complete with 90° Bend

.A45/.A46

NIKO Profile No.	23.000	24.000	25.000	26.000	27.000*
Right switch No.	23.A45	24.A45	25.A45	26.A45	27.A45
Left switch No.	23.A46	24.A46	25.A46	26.A46	27.A46
R (mm)	690/400	580/440	580	770	1035
b (mm)	700	700	800	1100	1350
b1 (mm)	770/530	700/590	760	980	1285
L1 (mm)	800/700	800/700	800	1000	1300
e (mm)	80/130	120/150	180	210	250

* Pneumatic cylinder is included.

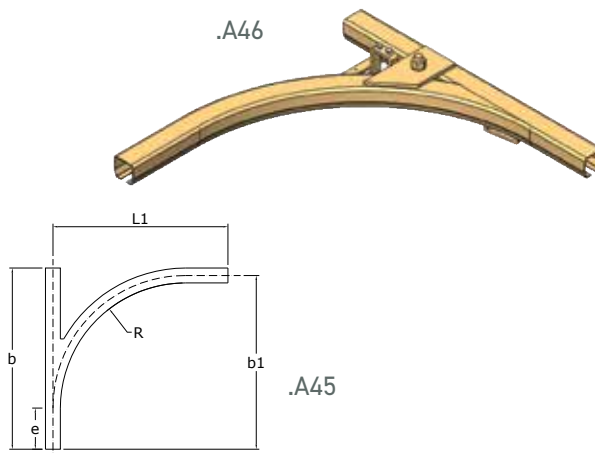

Single Tongue Switch complete with two Bends

.A47

NIKO Profile No.	23.000	24.000	25.000	26.000	27.000*
Part No.	23.A47	24.A47	25.A47	26.A47	27.A47
L1 (mm)	1405/1910	1400/1600	1530	2000	3000
b (mm)	530/775	575/692	755	980	1335
R (mm)	400/690	440/580	580	770	1035

* Pneumatic cylinder is included.

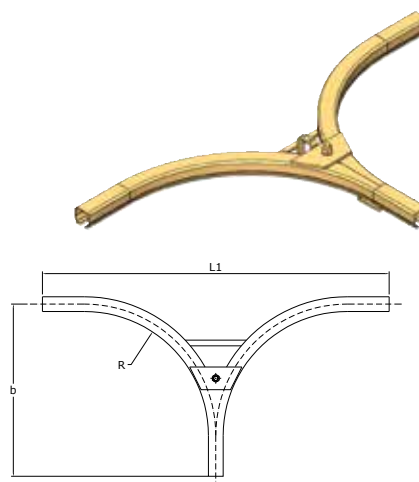

Triple Tongue Switch with two 90° Bends

.A15/.A16

NIKO Profile No.	23.000	24.000	25.000	26.000	27.000*	
Part No.	23.A15	24.A15	24.A16	25.A15	26.A15	27.A15
R (mm)	690	580	440	580	770	1035
b (mm)	770	700	590	760	980	1285
L (mm)	1540	1400	1180	1520	1960	2570
e (mm)	80	120	150	180	210	250

* Pneumatic cylinder is included.

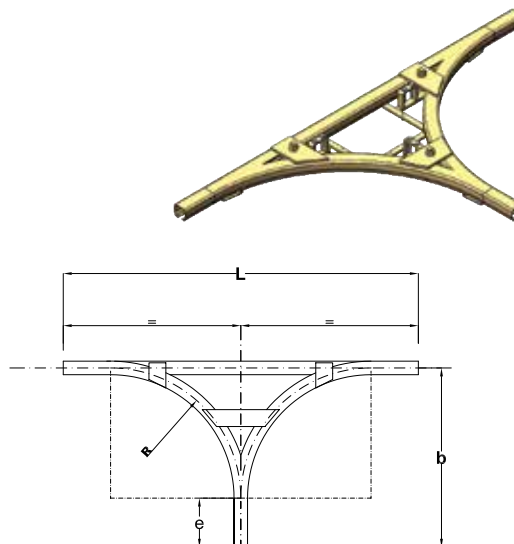

Automatic Single Tongue Switch Type A complete with Bend

.A06/.A07

In automatic swivel switch type A the trolleys come from the opposite direction to that indicated by the tongue. Possible directions : B to A and C to A.

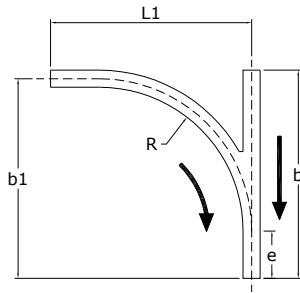
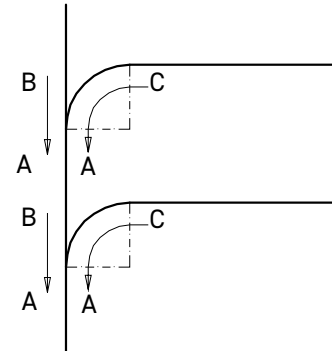
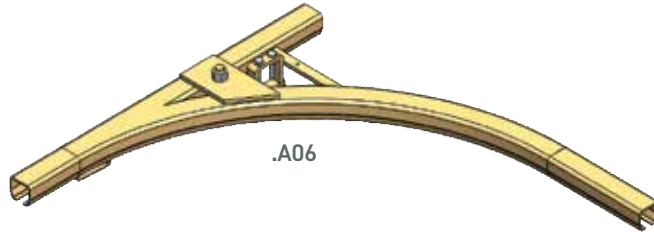

.A07

NIKO Profile No.	23.000	24.000	25.000	26.000	27.000*
Right switch No.	23.A06	24.A06	25.A06	26.A06	27.A06
Left switch No.	23.A07	24.A07	25.A07	26.A07	27.A07
R (mm)	690/400	580/440	580	770	1035
b (mm)	700	700	800	1100	1350
b1 (mm)	770/530	700/590	760	980	1285
L1 (mm)	800/700	800/700	800	1000	1300
e (mm)	80/130	120/150	180	210	250

*Pneumatic operation is included

Automatic Single Tongue Switch Type B complete with Bend

.A08/.A09

In automatic swivel switch type B the switch tongue is continuously pressed by a spring. This spring is positioned at the switch according to the required direction of product flow. Possible directions B to A, C to A or A to B.

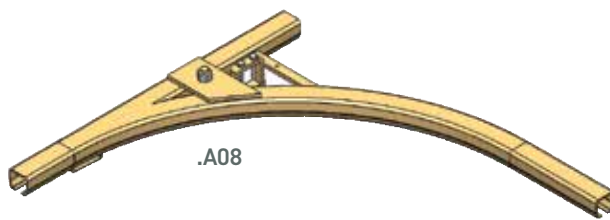

type 1. open straight line.

type 2. open track bend.

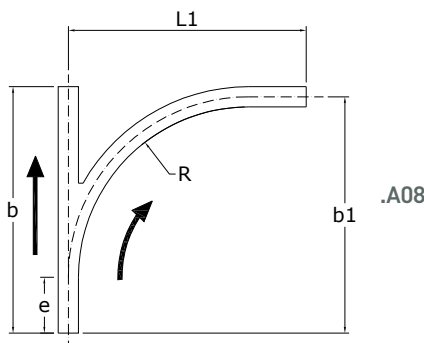
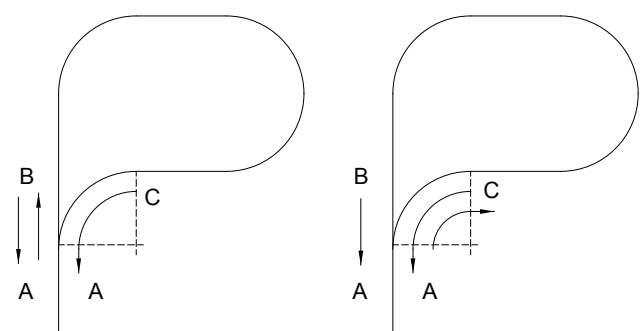

.A08

NIKO Profile No.	23.000	24.000	25.000	26.000	27.000*
Right switch No.	23.A08	24.A08	25.A08	26.A08	27.A08
Left switch No.	23.A09	24.A09	25.A09	26.A09	27.A09
R (mm)	690/400	580/440	580	770	1035
b (mm)	700	700	800	1100	1350
b1 (mm)	770/530	700/590	760	980	1285
L1 (mm)	800/700	800/700	800	1000	1300
e (mm)	80/130	120/150	180	210	250

*Pneumatic operation is included

Automatic Single Tongue Switch Type C complete with Bend

.A10/.A11

In automatic swivel switch type C the switch tongue leads the trolleys in different directions. When a trolley passes through the tongue automatically switches to the other direction. Possible directions: B to C and then A to C (or the opposite combination)

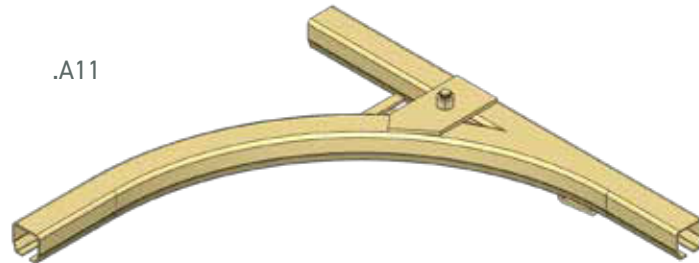
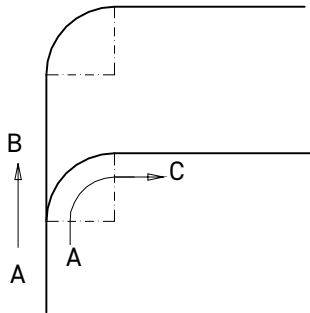

NIKO Profile No.	23.000	24.000	25.000	26.000	27.000*
Right switch No.	23.A10	24.A10	25.A10	26.A10	27.A10
Left switch No.	23.A11	24.A11	25.A11	26.A11	27.A11
R (mm)	690/400	580/440	580	770	1035
b (mm)	700	700	800	1100	1350
b1 (mm)	770/530	700/590	760	980	1285
L1 (mm)	800/700	800/700	800	1000	1300
e (mm)	80/130	120/150	180	210	250

*Pneumatic operation is included

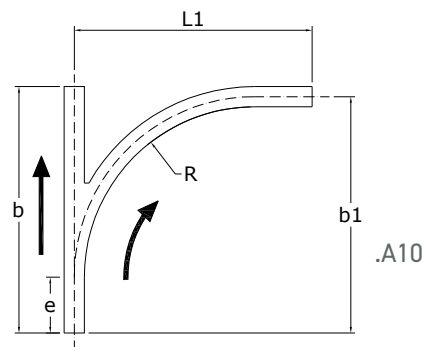

Cruciform Turn Table Switch

.A41

Turn table switches can be powered using motors or pneumatic cylinders.

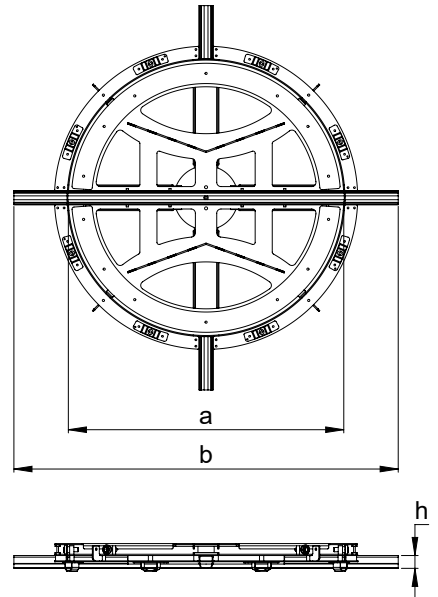
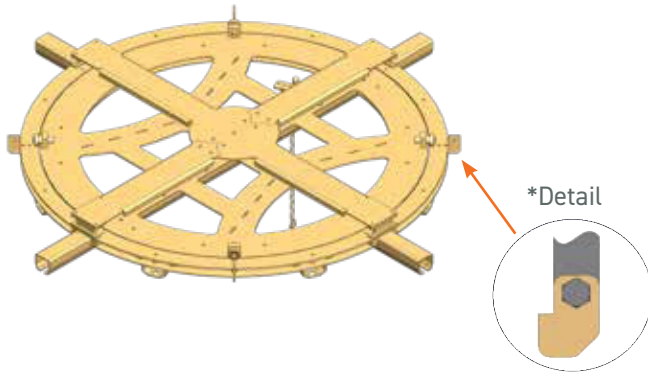

Can be provided in special dimensions upon request.

NIKO Profile No.	23.000	24.000	25.000	26.000	27.000
Part No.	23.A41	24.A41	25.A41	26.A41	27.A41
a (mm)	450	450	600	700	1000
b (mm)	700	850	1100	1300	1800
h (mm)	35	43.5	60	75	110

**Always support at eight points.*

Cruciform Turn Table Switch with electric operation

EL./ .A41

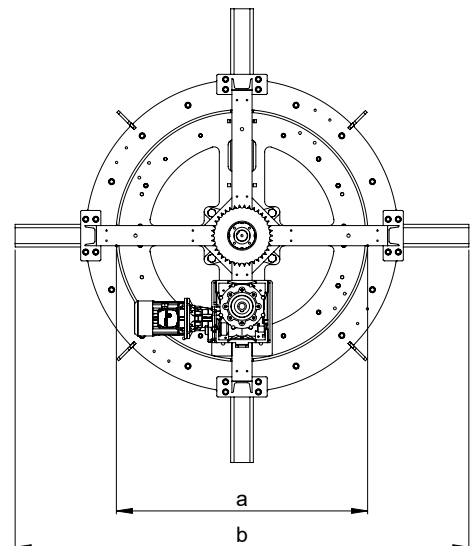
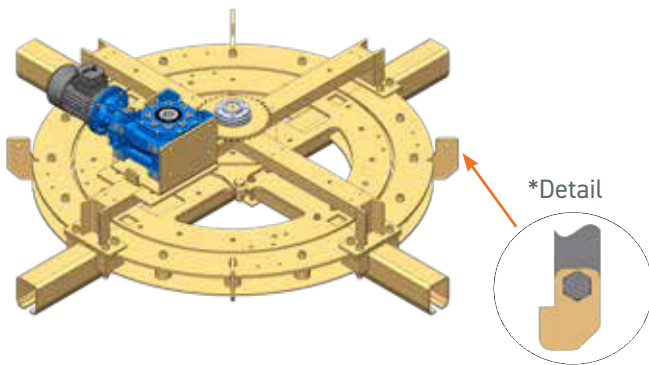

Can be provided in special dimensions upon request.

NIKO Profile No.	23.000	24.000	25.000	26.000	27.000
Part No.	EL.23.A41	EL.24.A41	EL.25.A41	EL.26.A41	EL.27.A41
a (mm)	450	450	600	700	1000
b (mm)	700	850	1100	1300	1800

**Always support at eight points.*

Cruciform Turn Table Switch with pneumatic operation

PN./A41

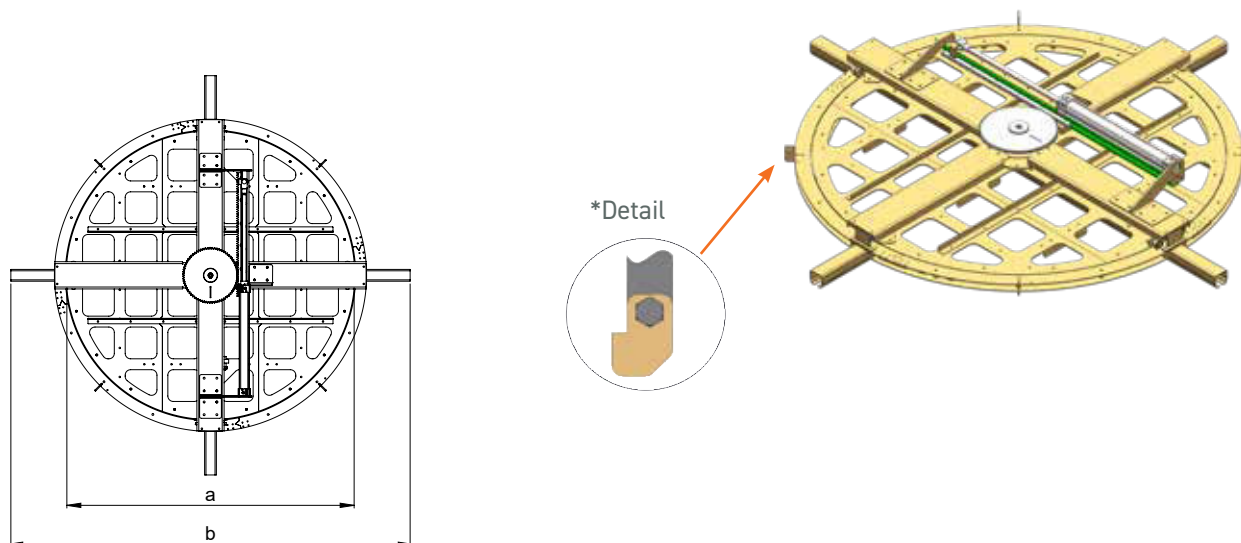

Can be provided in special dimensions upon request.

Profil Nr.	23.000	24.000	25.000	26.000
Art. Nr.	PN.23.A41	PN.24.A41	PN.25.A41	PN.26.A41
a (mm)	450	450	600	700
b (mm)	700	850	1100	1340

**Always support at eight points.*

Multiple Turn Table Switch

.A43

Turntable switches are robust constructions rotating on ball bearings, which are controlled by a chain operated system. The trolley enters the switch when it's locked in one of the positions of passage. These switches incorporate a safe construction that precludes the derailment of trolleys.

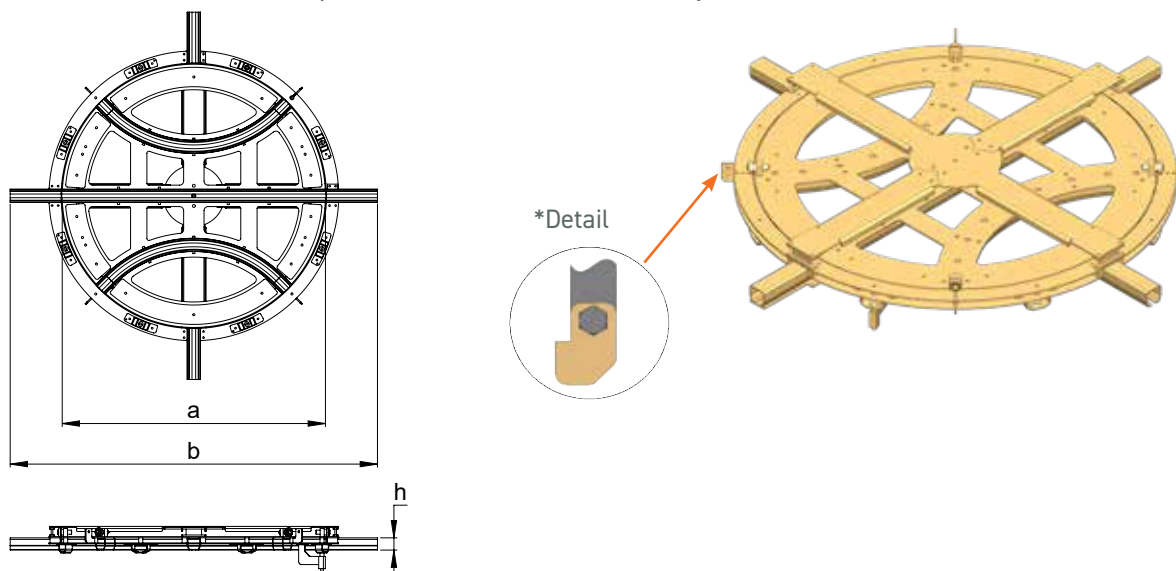

Profil Nr.	23.000	24.000	25.000	26.000	27.000
Art. Nr.	23.A43	24.A43	25.A43	26.A43	27.A43
a (mm)	900	900	1300	1600	2000
b (mm)	1300	1300	1800	2200	2800
h (mm)	35	43.5	60	75	110

Can be provided in special dimensions upon request.

**Always support at eight points.*

Conveyor Systems

We reserve the right for technical amendments without obligation.
The product pictures and drawings depicted in this catalogue do not always reflect all available sizes.

Pneumatic Turn Table Switch (incl. cylinder)

.A44/.A44D/.A44S

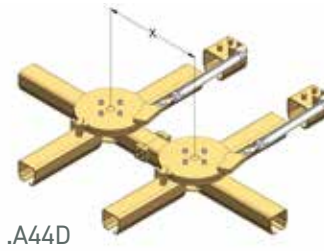
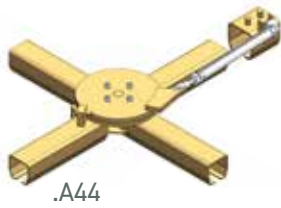

Detail view of .A44S for series 23-25.000



Detail view of .A44S for series 26-27.000

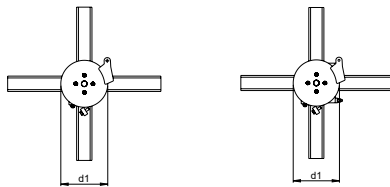
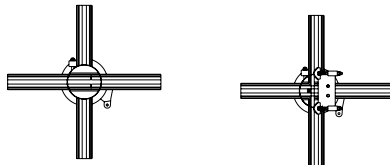

.A44

.A44S
(with
Positioning stoppers)

NIKO Profile No.	23.000	24.000	25.000	26.000	27.000
Part No.	23.A44	24.A44	25.A44	26.A44	27.A44
Part No.	23.A44S	24.A44S	25.A44S	26.A44S	27.A44S
b (mm)	500	500	700	800	1000
d1 (mm)	150	150	200	250	350

1. The pneumatic turn table switch .A44 is suitable for 90° rotation and transfer of trolleys.
2. The pneumatic turn table switch .A44S has an additional positioning feature, operated automatically, with springs (series 23-25.000) or manually, with a pneumatic cylinder, controlled by an additional separate valve (series 26-27.000).
3. The pneumatic turn table switch .A44D is a special editon for turn tables switches in line with smaller distance "X".

Articulation Joint

.H08

Placed at the end of the track and used for the lifting or lowering of loads. This function may be hand-operated or assisted by an electric hoist.

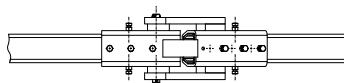
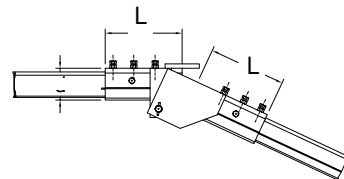

NIKO Profile No.	23.000	24.000	25.000	26.000	27.000
Part No.	23.H08	24.H08	25.H08	26.H08	27.H08
L (mm)	120	150	180	200	250

Ring Support Bracket

.H09

Used in combination with the articulation joint and connected directly to the electric hoist or any other manually operated load-lifting system.

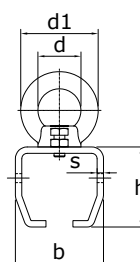
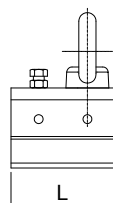

NIKO Profile No.	23.000	24.000	25.000	26.000	27.000
Part No.	23.H09	24.H09	25.H09	26.H09	27.H09
L (mm)	56	68	90	110	120
d ₁ (mm)	54	63	72	90	108
d (mm)	30	35	40	50	60
s (mm)	4	4,5	6	8	10
b (mm)	50	61	81	100	116
h (mm)	44	54	75	94	133

Spring Loaded Stopper

Provided tongue type: A,B,C,D (see below).

NIKO Profile No.	23.000	24.000	25.000	26.000
Part No.	23.H10	24.H10	25.H10	26.H10
L (mm)	50	60	90	110
h (mm)	78	80	120	145

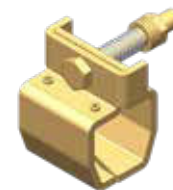
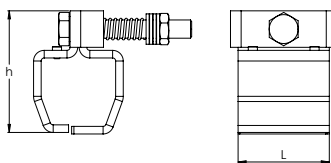

.H10

Directional Stopper

Provided tongue type: A,B,C,D (see below).

NIKO Profile No.	23.000	24.000	25.000	26.000	27.000
Part No.	23.H20	24.H20	25.H20	26.H20	27.H20
L (mm)	120	150	180	200	250
h (mm)	70	79	115	133	183

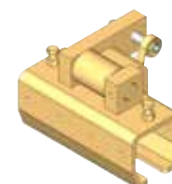
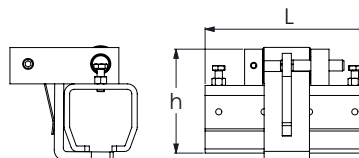

.H20

Stopper with Hand Lever

Used for the safe stopping of trolleys with track transfer assemblies and articulation units. There is a possibility of change in position following installation. The speed of trolleys must be reduced before they reach the stoppers. Provided tongue type: A,B,D (see below).

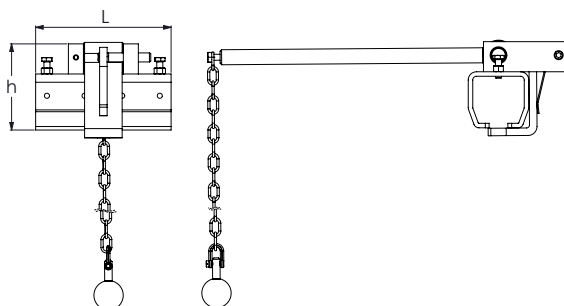

NIKO Profile No.	23.000	24.000	25.000	26.000	27.000
Part No.	23.H60	24.H60	25.H60	26.H60	27.H60
L (mm)	120	150	180	200	250
h (mm)	70	79	115	133	183

.H60

4 Types of tongues

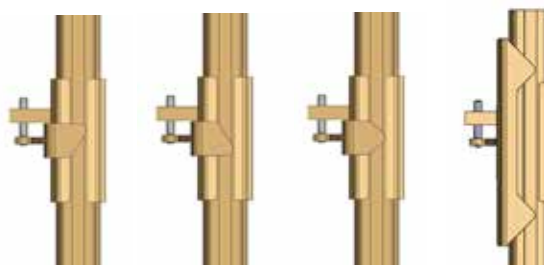

Type A.

Type B.

Type C.

Type D.

Pneumatic Stopper (incl.cylinder, w/o control switch)

NIKO Profile No.	23.000	24.000	25.000	26.000	27.000
Part No.	23.H63	24.H63	25.H63	26.H63	27.H63

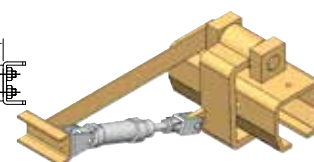
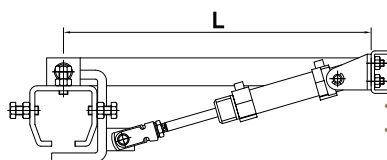

.H63

Track End Stop

.X01

The end stop with a rubber buffer is positioned at the end of the open profiles. Used in conjunction with a fixed cross bolt.

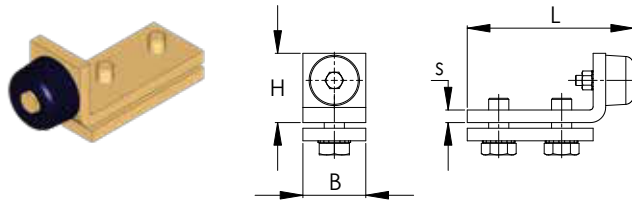

NIKO Profile No.	23.000	24.000	25.000	26./27.000
Part No.	23.X01	24.X01	25.X01	26.X01
L (mm)	70	75	120	130
B (mm)	20	30	40	50
H (mm)	24	30	47	60
s (mm)	4	5	8	10

Track cover

.X19

Track covers .X19 are only used for sealing the profile ends. Track end stoppers must not be omitted in case.

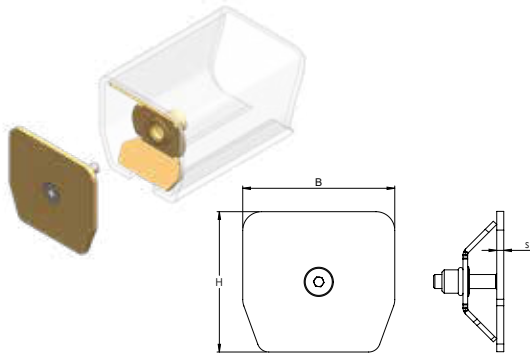

NIKO Profile No.	21.000	23.000	24.000	25.000	26.000	27.000
Part No.	21.X19	23.X19	24.X19	25.X19	26.X19	27.X19
B (mm)	30	40	48.5	65	80	90
H (mm)	28	35	43.5	60	75	110
s (mm)	3	3	3	3	3	3

Dilation Joint

.H30

A dilation joint is necessary inside the heat treatment areas to accommodate any possible thermal expansion/contraction of track profiles. Dilation joint is not provided as galvanized.

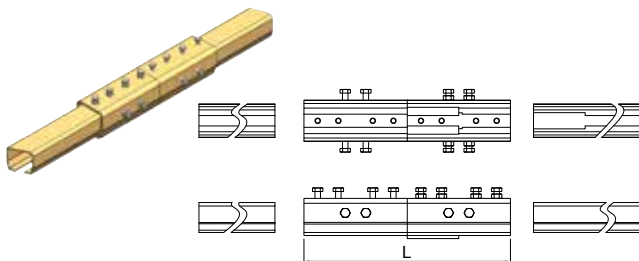

NIKO Profile No.	23.000	24.000	25.000	26.000	27.000
Part No.	23.H30	24.H30	25.H30	26.H30	27.H30
L (mm)	240	300	360	400	500

Manual Lateral Swivel Unit

.H15/.H25

Permits interruption of the transport line from sliding or opening doors. The transport line reverts to its normal position following the opening of the door.

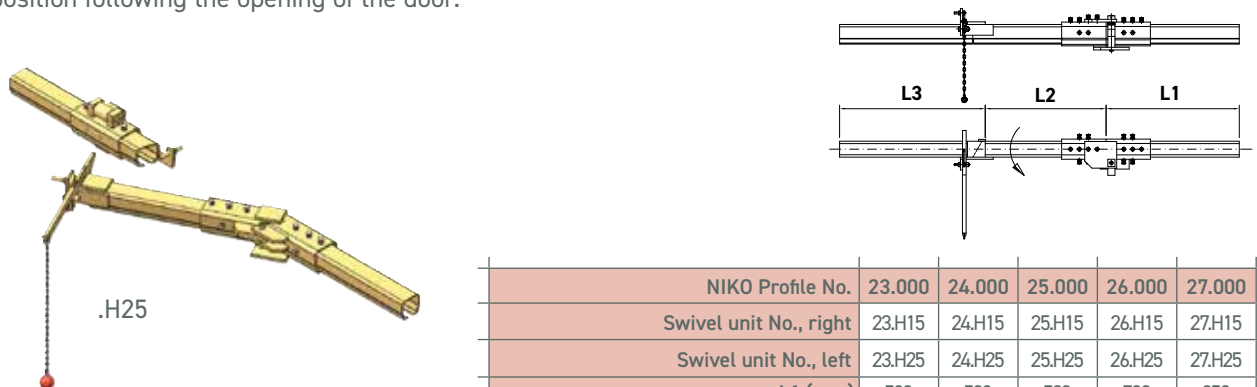

NIKO Profile No.	23.000	24.000	25.000	26.000	27.000
Swivel unit No., right	23.H15	24.H15	25.H15	26.H15	27.H15
Swivel unit No., left	23.H25	24.H25	25.H25	26.H25	27.H25
L1 (mm)	500	500	500	700	850
L2 (mm)	500	500	500	500	600
L3 (mm)	500	500	500	700	850

Pneumatic Lateral Swivel Unit (incl. cylinder without control switch)

.H16/.H26

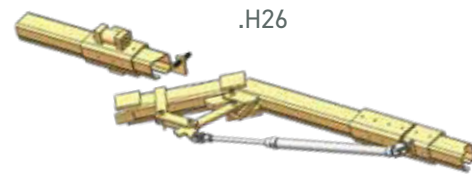
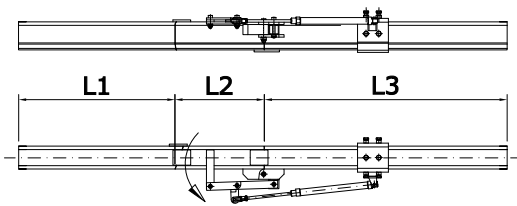

NIKO Profile No.	23.000	24.000	25.000	26.000	27.000
Swivel unit No., right	23.H16	24.H16	25.H16	26.H16	27.H16
Swivel unit No., left	23.H26	24.H26	25.H26	26.H26	27.H26
L1 (mm)	500	500	500	700	900
L2 (mm)	350	350	350	400	450
L3 (mm)	500	500	500	700	900

Spring Loaded Lateral Swivel Unit

.H17/.H27

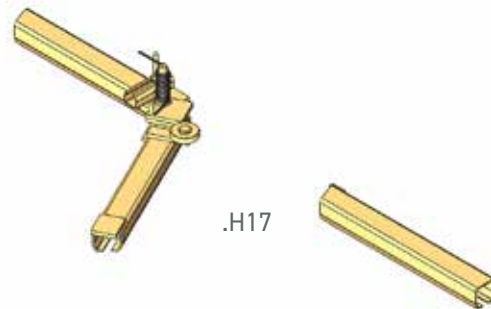
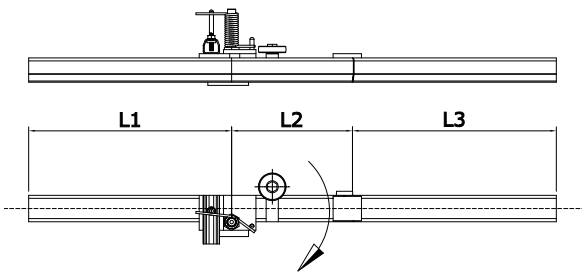

NIKO Profile No.	23.000	24.000	25.000	26.000
Swivel unit No., right	23.H17	24.H17	25.H17	26.H15
Swivel unit No., left	23.H27	24.H27	25.H27	26.H27
L1 (mm)	500	500	500	700
L2 (mm)	300	300	350	400
L3 (mm)	500	500	500	700

Pneumatic Vertical Swivel Unit Upward

.H18

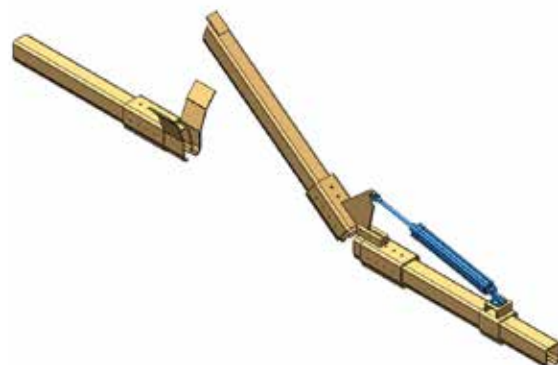
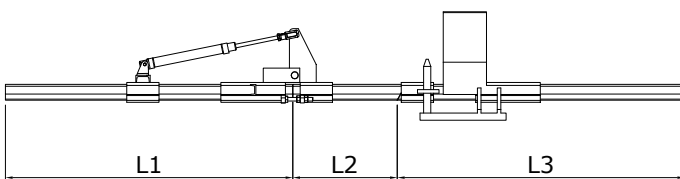

NIKO Profile No.	23.000	24.000	25.000	26.000	27.000
Swivel No.	23.H18	24.H18	25.H18	26.H18	27.H18

Bridge Interlock (safety plate must be installed) (Part 1)

.H01

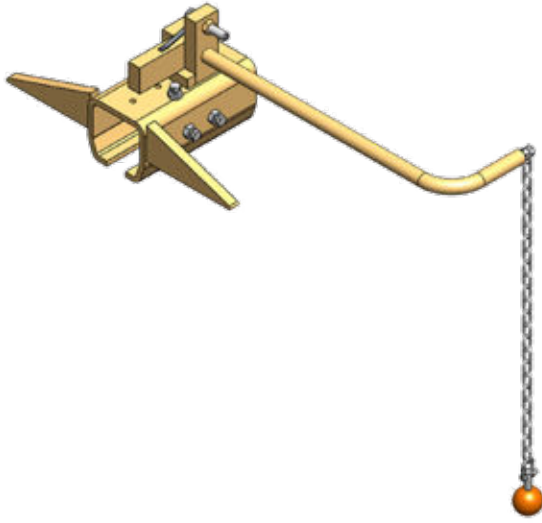

NIKO Profile No.	23.000	24.000	25.000	26.000	27.000
Part No.	23.H01	24.H01	25.H01	26.H01	27.H01
a (mm)	50	61	81	100	116
h (mm)	44	54	75	94	133
l (mm)	120	150	180	200	250
H (mm)	117	126	170	188	229

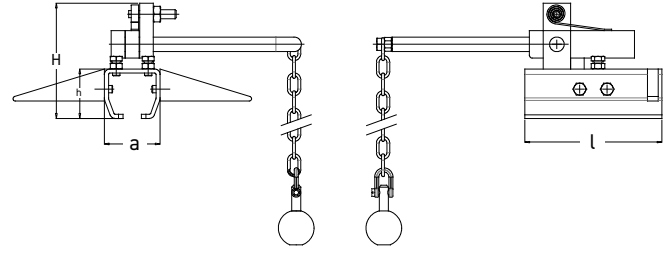

Bridge Interlock (safety plate must be installed) (Part 2)

.H02

CONVEYOR SYSTEMS

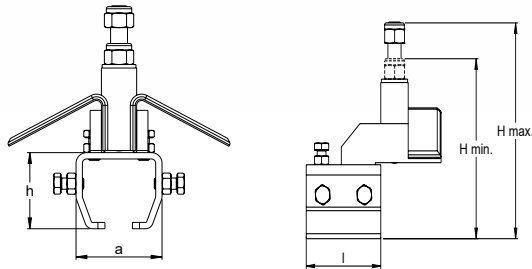
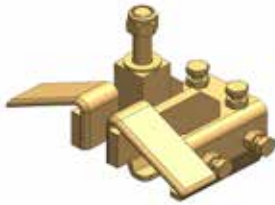

NIKO Profile No.	23.000	24.000	25.000	26.000	27.000
Part No.	23.H02	24.H02	25.H02	26.H02	27.H02
a (mm)	50	61	81	100	116
h (mm)	44	54	75	94	133
l (mm)	56	68	90	110	120
H min (mm)	117	127	168	186	291
H max (mm)	147	157	210	233	360

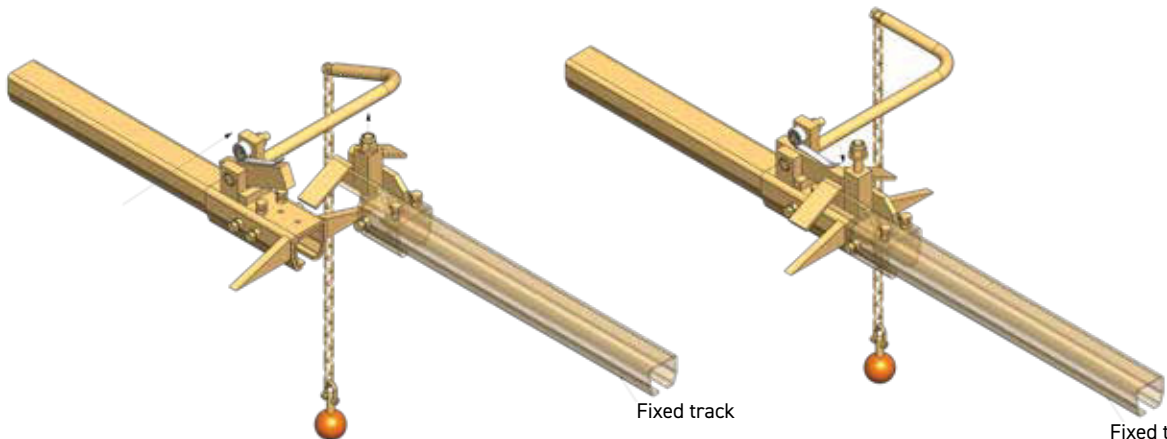

Track transfer assembly (Part 1) (no safety plate required)

.H21

NIKO Profile No.	24.000	25.000	26.000	27.000
Part No.	24.H21	25.H21	26.H21	27.H21
B (mm)	190	230	260	400
H (mm)	160	220	255	295
L (mm)	150	180	200	250
L1 (mm)	210	230	245	320

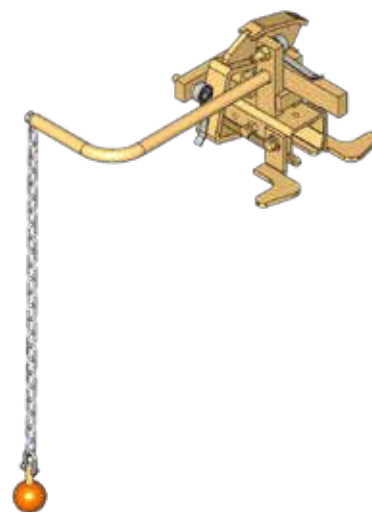
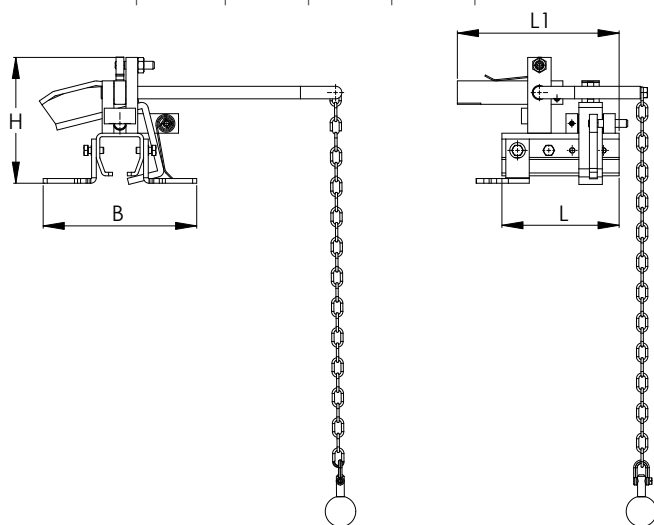

Track transfer assembly (Part 2) (no safety plate required)

.H22

NIKO Profile No.	24.000	25.000	26.000	27.000
Part No.	24.H22	25.H22	26.H22	27.H22
B (mm)	225	280	300	400
H (mm)	215	260	315	370
L (mm)	150	180	200	250
L1 (mm)	285	320	365	460

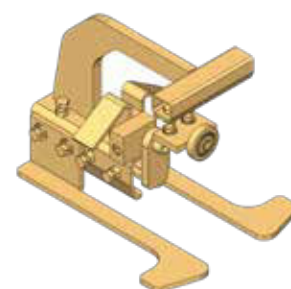
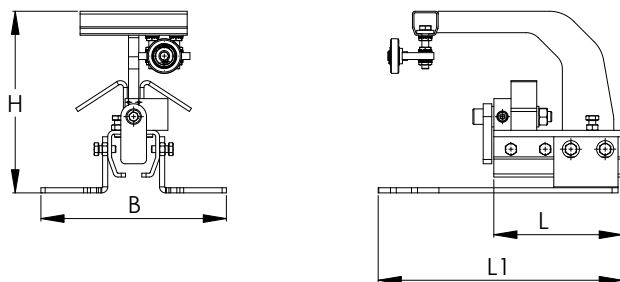

Drop Lift Unit

Standard Drop-Lift (.H70)

The drop-lift station is supplied as complete kit, including all necessary safety obligations concerning safety of the flight bar.

The drop-lift station is no subjection to elevator/lift regulations, because it is used exclusively and only for the transport of goods and is part of a conveyor system.

At both fixed ends of the entrance and exit of the movable track piece there are additional mechanical and pneumatic devices, which close the open ends (when the movable track piece is not in motion). These devices also stop any movement of load carriers, that approach the drop-lift station from the conveyor system.

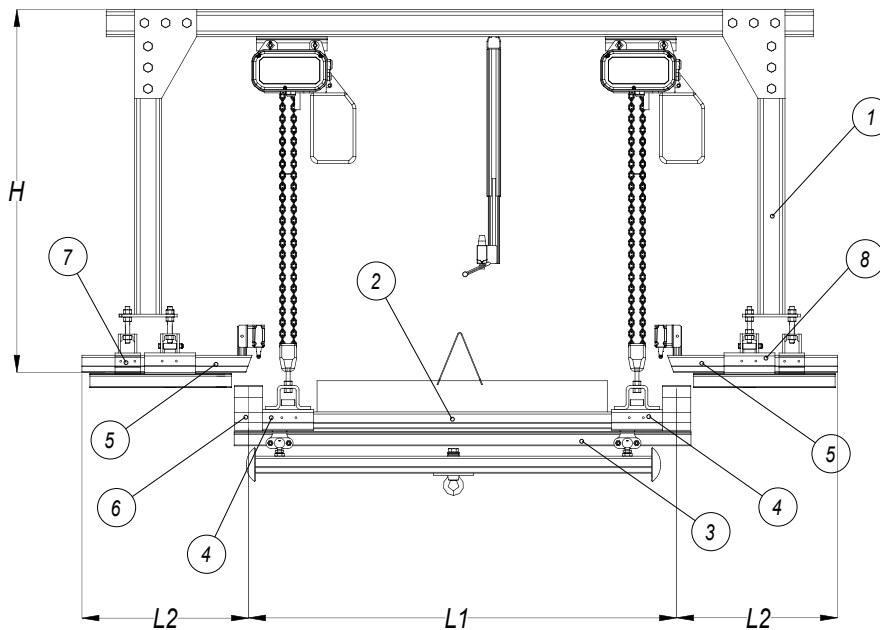
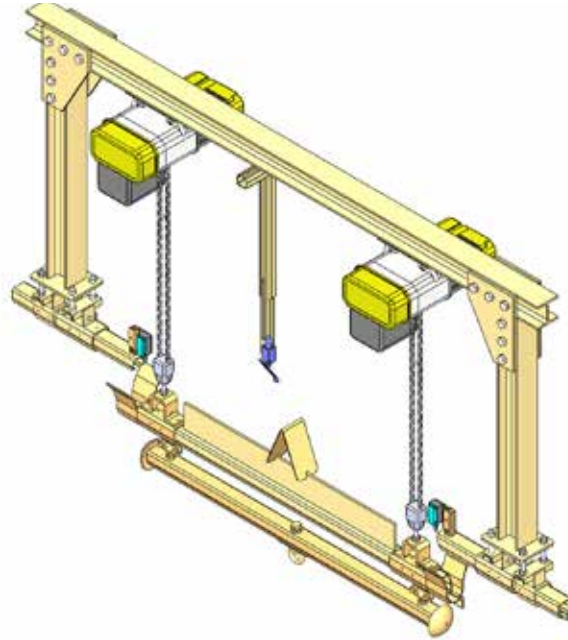

NIKO Profile No.	24.000	25.000	26.000	27.000
Drop-lift No.	24.H70	25.H70	26.H70	27.H70
Min L1 (mm)	1000	1000	1000	1000
L2 (mm)	550	650	750	900
H (mm)	1150	1200	1250	1350
SWL (kg)	160	400	800	1600

CONVEYOR SYSTEMS

Low Headroom Drop Lift (.H71)

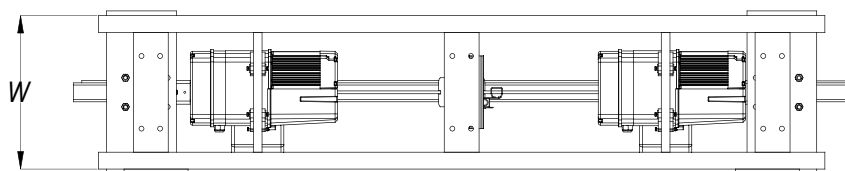
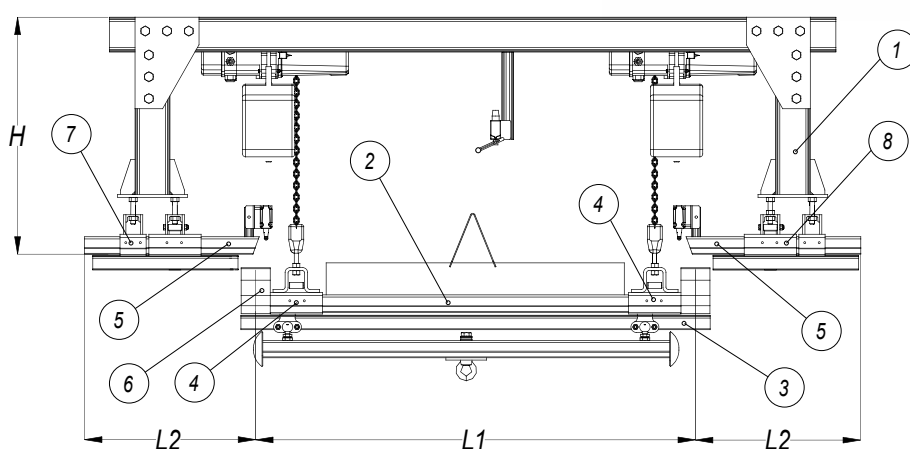
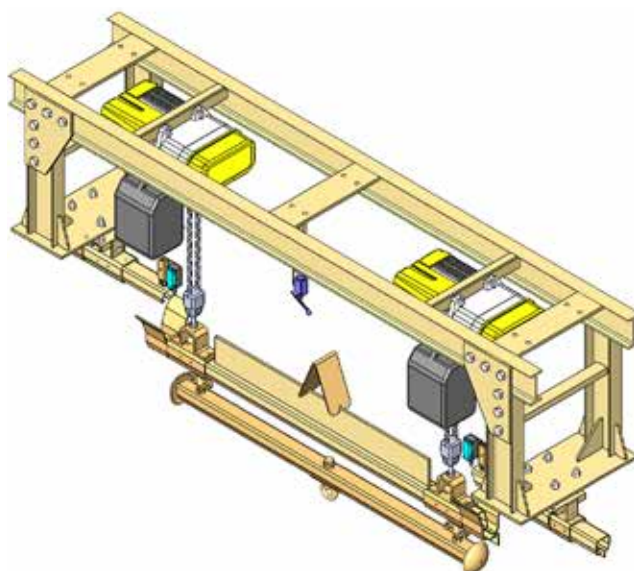

NIKO Profile No.	24.000	25.000	26.000	27.000
Drop-lift No.	24.H71	25.H71	26.H71	27.H71
Min L1 (mm)	1000	1000	1000	1000
L2 (mm)	550	650	750	900
H (mm)	850	900	950	1050
SWL (kg)	160	400	800	1600
W (mm)	600	600	700	700

Drop Lift Main Features:

- 1 Mounting frame for the drop-lift station, consisting of beams. (f/n 1).
- 1 Track with diagonally cut ends (moving track piece/ lifting track for rise and descent) (f/n 2).
- 1 Security angled rail with notches for securing and holding the load carrier in place in the lifting track at the rise and descent (f/n 3).
- 2 Special connections for suspension with pressure spring for securing the security angled rail during the rise and descent (f/n 4).
- 2 Fixed track pieces with diagonally cut ends on both sides of the lifting track (f/n 5).
- 2 driver parts for the correct steering and alignment of the lifting track (f/n 6).
- 2 Special adjustable supports for securing the fixed track parts (f/n 7).
- 2 Special pneumatic safety devices for securing/unlocking the security angled rail and bracing of the fixed track pieces (f/n 8).

NIKO Track Profiles, stainless steel

STAINLESS STEEL
304

STAINLESS STEEL
316

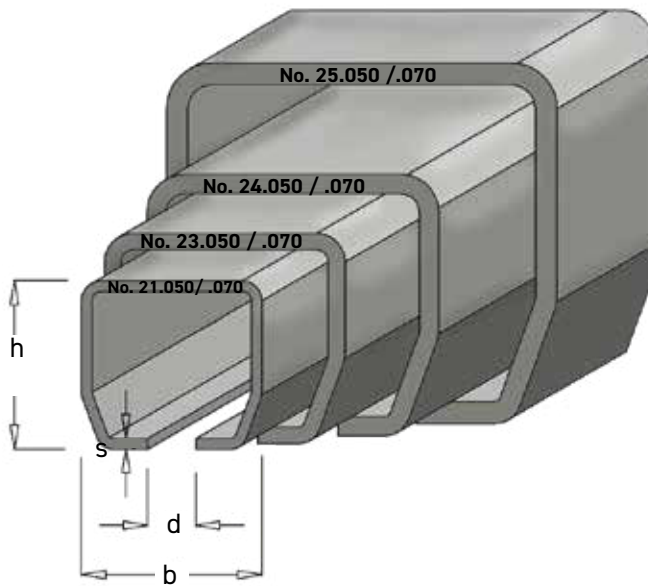

NIKO Profil No.	Dimensions			
	h (mm)	b (mm)	d (mm)	s (mm)
21.050 Stainless steel (304)	28,00	30,00	8,00	1,75
21.070 Stainless steel (316)	28,00	30,00	8,00	1,75
23.050 Stainless steel (304)	35,00	40,00	11,00	3,00
23.070 Stainless steel (316)	35,00	40,00	11,00	3,00
24.050 Stainless steel (304)	43,50	48,50	15,00	3,20
24.070 Stainless steel (316)	43,50	48,50	15,00	3,20
25.050 Stainless steel (304)	60,00	65,00	18,00	4,00
25.070 Stainless steel (316)	60,00	65,00	18,00	4,00

Track bends, stainless steel

STAINLESS STEEL
304

STAINLESS STEEL
316

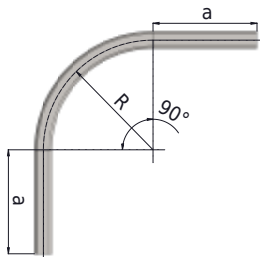

NIKO Profile No.	21.050/.070	23.050/.070	24.050/.070	25.050/.070
Track bend 90° No. (304)	51.C06	53.C07	54.C06	55.C06
Track bend 90° No. (316)	71.C06	73.C07	74.C06	75.C06
a (mm)	425±20	390±20	505±20	520±20
R (mm)	730±25	780±25	630±25	610±25
L (mm)	2000	2000	2000	2000

NIKO Profile No.	21.050/.070	21.050/.070	21.050/.070	23.050/.070	24.050/.070	
Track bend 90° No. (304)	51.C02	51.C03	51.C04	53.C04	54.C04	54.C09
Track bend 90° No. (316)	71.C02	71.C03	71.C04	73.C04	74.C04	74.C09
a (mm)	580±20	500±20	670±20	670±20	640±20	465±30
R (mm)	220±25	320±25	420±25	420±25	460±25	1000±30
L (mm)	1500	1500	2000	2000	2000	2500

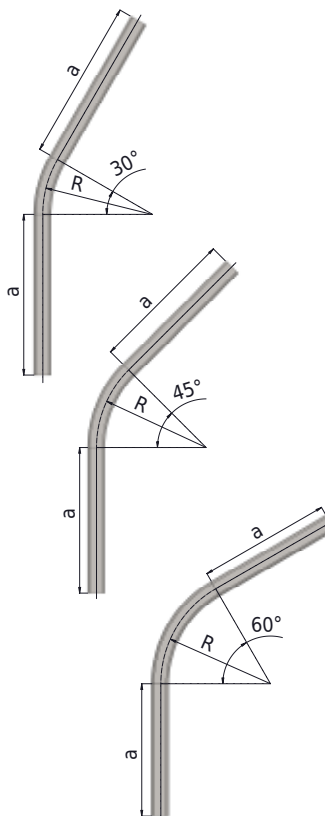

NIKO Profile No.	21.050/.070	23.050/.070	24.050/.070	25.050/.070
Track bend 60° No. (304)	51.C16	53.C17	54.C16	54.C19
Track bend 60° No. (316)	71.C16	73.C17	74.C16	74.C19
a (mm)	620±20	590±20	670±20	475±30
Track bend 45° No. (304)	51.C26	53.C27	54.C26	54.C29
Track bend 45° No. (316)	71.C26	73.C27	74.C26	74.C29
a (mm)	715±20	690±20	750±20	605±30
Track bend 30° No. (304)	51.C36	53.C37	54.C36	54.C39
Track bend 30° No. (316)	71.C36	73.C37	74.C36	74.C39
a (mm)	810±20	795±20	835±20	740±30
R (mm)	730±25	780±25	630±25	1000±30
L (mm)	2000	2000	2000	2000

NIKO Profile No.	21.050/.070	23.050/.070	24.050/.070
Track bend 60° No. (304)	51.C12	51.C14	53.C14
Track bend 60° No. (A4)	71.C12	71.C14	73.C14
a (mm)	635±20	780±20	780±20
Track bend 45° No. (304)	51.C22	51.C24	53.C24
Track bend 45° No. (316)	71.C22	71.C24	73.C24
a (mm)	665±20	835±20	835±20
Track bend 30° No. (304)	51.C32	51.C34	53.C34
Track bend 30° No. (316)	71.C32	71.C34	73.C34
a (mm)	690±20	890±20	890±20
R (mm)	220±25	420±25	420±25
L (mm)	1500	2000	2000

Splice joint

.B49

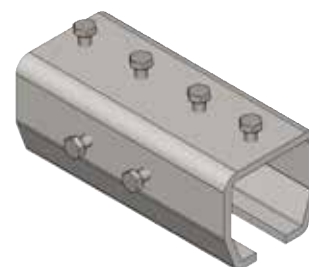

NIKO Profile No.	51./71.000	53./73.000	54./74.000	55./75.000
Part No. (304)	51.B49	53.B49	54.B49	55.B49
Part No. (316)	71.B49	73.B49	74.B49	75.B49

See product dimensions in page 14.

Support bracket

.B00



NIKO Profile No.	51./71.00	53./73.000	54./74.000	55./75.000
Part No. (304)	51.B00	53.B00	54.B00	55.B00
Part No. (316)	71.B00	73.B00	74.B00	75.B00

See product dimensions in page 14.

Ceiling support bracket

.B02

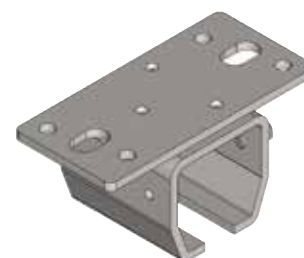

NIKO Profile No.	51./71.00	53./73.000	54./74.000	55./75.000
Part No. (304)	51.B02	53.B02	54.B02	55.B02
Part No. (316)	71.B02	73.B02	74.B02	75.B02

See product dimensions in page 15.

Wall Support Bracket

.B01



NIKO Profile No.	51./71.00	53./73.000	54./74.000	55./75.000
Part No. (304)	51.B01	53.B01	54.B01	55.B01
Part No. (316)	71.B01	73.B01	74.B01	75.B01

See product dimensions in page 14.

Conveyor Systems

We reserve the right for technical amendments without obligation.
The product pictures and drawings depicted in this catalogue do not always reflect all available sizes.

Split support bracket

.B03



NIKO Profile No.	51./71.000	53./73.000	54./74.000	55./75.000
Part No. (304)	51.B03	53.B03	54.B03	55.B03
Part No. (316)	71.B03	73.B03	74.B03	75.B03

See product dimensions in page 15.

Adjustable bracket

.B04



NIKO Profile No.	51./71.000	53./73.000	54./74.000	55./75.000
Part No. (304)	51.B04	53.B04	54.B04	55.B04
Part No. (316)	71.B04	73.B04	74.B04	75.B04

See product dimensions in page 16.

I-Beam girder clamp

.B37



NIKO Profile No.	51./71.000	53./73.000
Part No. (304)	51.B37	53.B37
Part No. (316)	71.B37	73.B37

See product dimensions in page 18.

Adjustable bracket with ceiling support

.B44



NIKO Profile No.	23.050/.070	24.050/.070	25.050/.070
Part No. (304)	53.B44	54.B44	55.B44
Part No. (316)	73.B44	74.B44	75.B44

See product dimensions in page 20.

Ceiling support bracket

.Z08



NIKO Profile No.	24.050/.070	25.050/.070
Part No. (304)	54.Z08	55.Z08
Part No. (316)	74.Z08	75.Z08

See product dimensions in page 20.

Adjustable joist clamp with support bracket (Parallel and 90° to the I-beam)

.B35/.B36

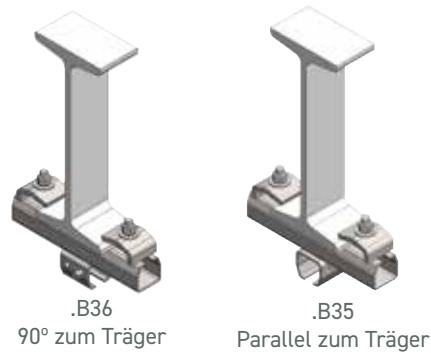

NIKO Profile No.	23.050/.070	24.050/.070	25.050/.070
Part No. (304)	53.B35/.B36	54.B35/.B36	55.B35/.B36
Part No. (316)	73.B35/.B36	74.B35/.B36	75.B35/.B36

See product dimensions in page 21.

Adjustable joist clamp with splice joint (Parallel and 90° to the I-beam)

.B71/.B72

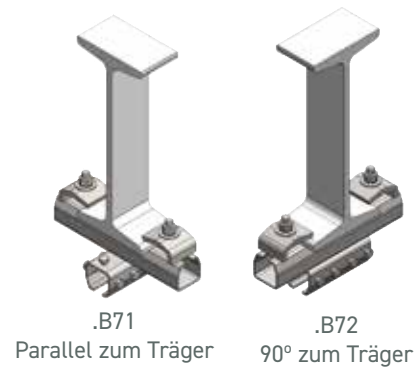

NIKO Profile No.	23.050/.070	24.050/.070	25.050/.070
Part No. (304)	53.B71/.B72	54.B71/.B72	55.B71/.B72
Part No. (316)	73.B71/.B72	74.B71/.B72	75.B71/.B72

See product dimensions in page 21.

4-Wheel Trolley for Welding

.T00

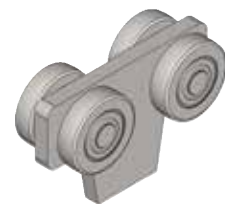

NIKO Profile No.	51./71.00	53./73.000	54./74.000	55./75.000
Part No. (304)	51.T00	53.T00	54.T00	55.T00
Part No. (316)	71.T00	73.T00	74.T00	75.T00

See product dimensions in page 24.

2-Wheel Trolley for Welding

.T01



NIKO Profile No.	51./71.00	53./73.000	54./74.000	55./75.000
Part No. (304)	51.T01	53.T01	54.T01	55.T01
Part No. (316)	71.T01	73.T01	74.T01	75.T01

See product dimensions in page 24.

Conveyor Systems

We reserve the right for technical amendments without obligation.
The product pictures and drawings depicted in this catalogue do not always reflect all available sizes.

4-Wheel Trolley with Hole

.T10



NIKO Profile No.	51./71.000	53./73.000	54./74.000	55./75.000
Part No. (304)	51.T10	53.T10	54.T10	55.T10
Part No. (316)	71.T10	73.T10	74.T10	75.T10

See product dimensions in page 24.

2-Wheel Trolley with Hole

.T11



NIKO Profile No.	51./71.000	53./73.000	54./74.000	55./75.000
Part No. (304)	51.T11	53.T11	54.T11	55.T11
Part No. (316)	71.T11	73.T11	74.T11	75.T11

See product dimensions in page 25.

4-Wheel Trolley with a Rotating Eye Nut DIN 582

.T40

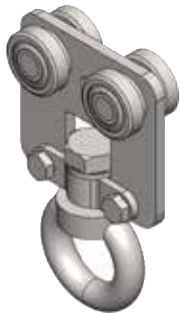

NIKO Profile No.	53./73.000	54./74.000	55./75.000
Part No. (304)	53.T40	54.T40	55.T40
Part No. (316)	73.T40	74.T40	75.T40

See product dimensions in page 30.

4-Wheel Trolley with Pin and Buffer (plate)

.T48

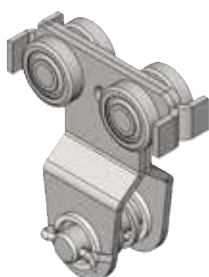

NIKO Profile No.	54./74.000	55./75.000
Part No. (304)	54.T48	55.T48
Part No. (316)	74.T48	75.T48

See product dimensions in page 31.

Trolley with Stainless Steel Hook

.T21/.T18



NIKO Profile No.	54./74.000	55./75.000
Part No. (304)	54.T21	55.T21
Part No. (316)	74.T21	75.T21
Part No. (304)	54.T18	-
Part No. (316)	74.T18	-

See product dimensions in page 33.



4-Wheel Trolley with Rotating Screw

.T14



NIKO Profile No.	54./74.000	55./75.000
Part No. (304)	54.T14	55.T14
Part No. (316)	74.T14	75.T14

See product dimensions in page 27.



Flight Bar with Fixed Eye Nut

.T24



NIKO Profile No.	54./74.000	55./75.000
Part No. (304)	54.T24	55.T24
Part No. (316)	74.T24	75.T24

See product dimensions in page 33.

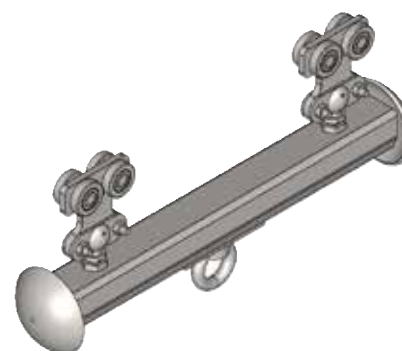

Flight Bar with Rotating Eye Nut

.T26



Profil Nr.	54./74.000	55./75.000
Art. Nr. (304)	54.T26	55.T26
Art. Nr. (316)	74.T26	75.T26

See product dimensions in page 34.

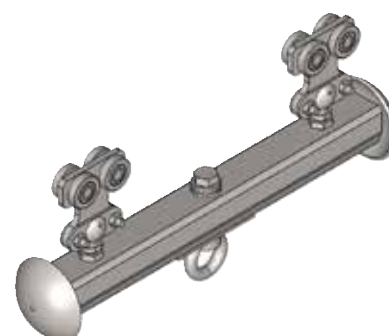

Conveyor Systems

We reserve the right for technical amendments without obligation.
The product pictures and drawings depicted in this catalogue do not always reflect all available sizes.

Single Tongue Switch complete with 90° Bend

.A45/.A46

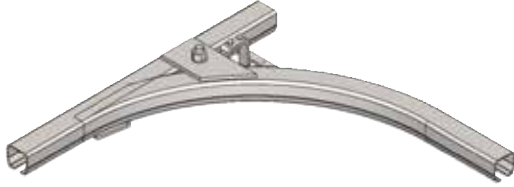

NIKO Profile No.	54./74.000	55./75.000
Part No. (304)	54.A45	55.A45
Part No. (316)	74.A45	75.A45
Part No. (304)	55.A46	55.A46
Part No. (316)	75.A46	75.A46

See product dimensions in page 43.

Single Tongue Switch complete with 60° Bend

.A02/.A03



NIKO Profile No.	54./74.000	55./75.000
Part No. (304)	54.A02	55.A02
Part No. (316)	74.A02	75.A02
Part No. (304)	54.A03	55.A03
Part No. (316)	74.A03	75.A03

See product dimensions in page 40.

CONVEYOR SYSTEMS

Switch Lever

A50.(DL.)



NIKO Profile No.	54./74.000	55./75.000
Part No. (304)	54.A50	55.A50
Part No. (316)	74.A50	75.A45

See product dimensions in page 42.

Track End Stop

.X01



NIKO Profile No.	53./73.000	54./74.000	55./75.000
Part No. (304)	53.X01	54.X01	55.X01
Part No. (316)	73.X01	74.X01	75.X01

See product dimensions in page 50.

Our quality control department is manned by experienced and highly skilled engineers. Our test lab is equipped with endurance test stands, tensile stress equipment, hardness test machines and other laboratory equipment. Finite Element Analysis is also performed during the developing phase of every component.

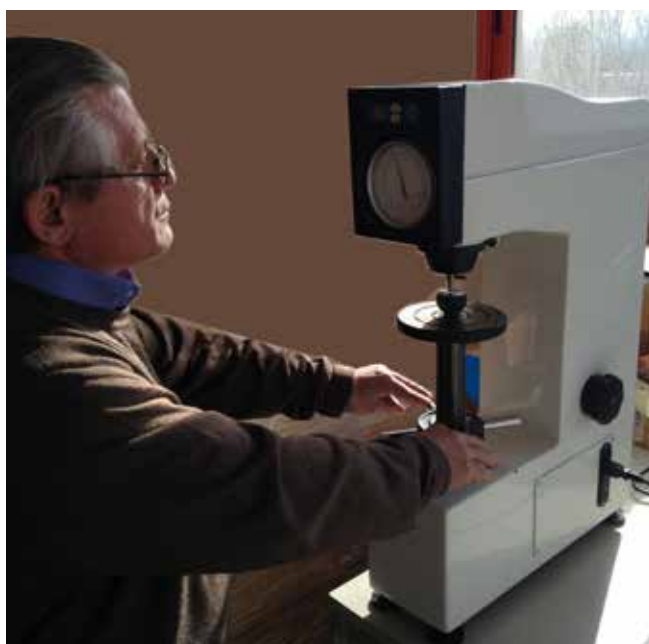

CONVEYOR SYSTEMS





AUSTRIA-
NIKO Vertriebs GmbH
Hainfelder Straße 48
A - 2560 Berndorf
Tel. 0043 (0) 2672 21201
Fax 0043 (0) 2672-21201-13
office.at@niko.eu.com
www.niko.world

POLAND-
NIKO Polska
Skrzynno 192a
Ostrowek 98-311
Tel. +48 504 003 556
info.pl@niko.eu.com
www.niko.world

GREECE-
Helm Hellas S.A.
82nd Km Athens-Korinthos
P.O. Box 209
GR - 201 00 KORINTHOS
Tel. 0030 27410 76800
Fax 0030 27410 25368
info@niko.eu.com
www.niko.eu.com

NIKO Conveyors
597 Middle Street
Bristol, CT 06010
Tel. 001 860-845-8179
info@NIKOconveyors.com
www.nikoconveyors.com

NikoTrack/NIKO US
9 Stockholm St,
Newport RI 02840
C: 401-835-8640
Alex.Koza@niko.eu.com
alex@nikotrack.com
www.nikotrack.com

CANADA -
NIKO Crane Canada
615, rue du Nickel
Québec (Québec) G2N 0J9
Tel. 418 841.2287
info@smakdesign.ca
www.smakmanutention.com

UNITED KINGDOM-
NIKO Ltd
Airfield Park Business Park
Welsh Road East, Southam
Warwickshire, CV47 1NE
Tel. 0044 (0) 1926 813111
Fax 0044 (0) 1926 815599
Sales@niko.co.uk
www.niko.co.uk

USA Light Crane Systems-
NIKORAIL
8000 Joliet Rd.
McCook, IL 60525
Toll Free 888.352.1213
Tel. 001 708-352-1213
sales@hsicrane.com
www.nikorail.com

GERMANY-
NIKO Technik GmbH
Robert-Bosch-Str. 14
DE - 42489 Wülfrath
Tel. 0049 (0) 2058 9093603
Fax 0049 (0) 2058 9093604
office.de@niko.eu.com
www.niko.world

CHINA-
NIKO TRADING (SHANGHAI) Co., Ltd
Room 901-156, No.18
Tianshan Road, Changning District,
P.R.China - 201802 Shanghai
Tel. 0086 134 2785 9785
info.cn@niko.eu.com

www.niko.eu.com

Your **NIKO** agent will be happy to advise you:



Complete product range **NIKO**:

- Light duty sliding door hardware
- Heavy duty sliding door hardware
- Conveyor systems
- Light cranes
- Cable trolleys, festoon systems & conductor bars
- Personal fall arrest systems (EN 795)
- Accessories for gates and doors