

NIKO Aluminium Light Crane Systems

NIKO ... Quality in Motion





Company Profile

Established in 1972, NIKO is focused on designing, developing, producing and marketing high quality sliding door fittings and handling systems at the right price. NIKO currently has a direct presence in 7 countries and indirectly through our representatives to more than 65 countries worldwide.

Our product range includes more than 10.000 different assemblies & components making us capable of providing complete solutions to different industries worldwide. Our team of highly qualified engineers are continually working to improve our current product portfolio & extend it according to market requirements.

NIKO enforces a continuous quality control program and is certified according to ISO:9001 and ISO:14001.

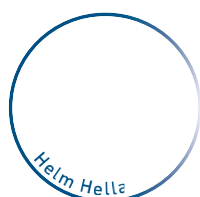



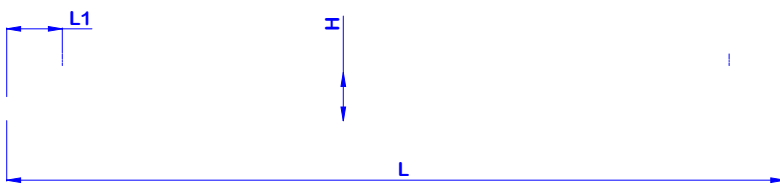

NIKO Aluminium Cranes - Freestanding Applications

Typical Layout Configuration 1

.B35*
Adjustable
joist clamp
(parallel)

.B71*
(parallel)

Configuration 2



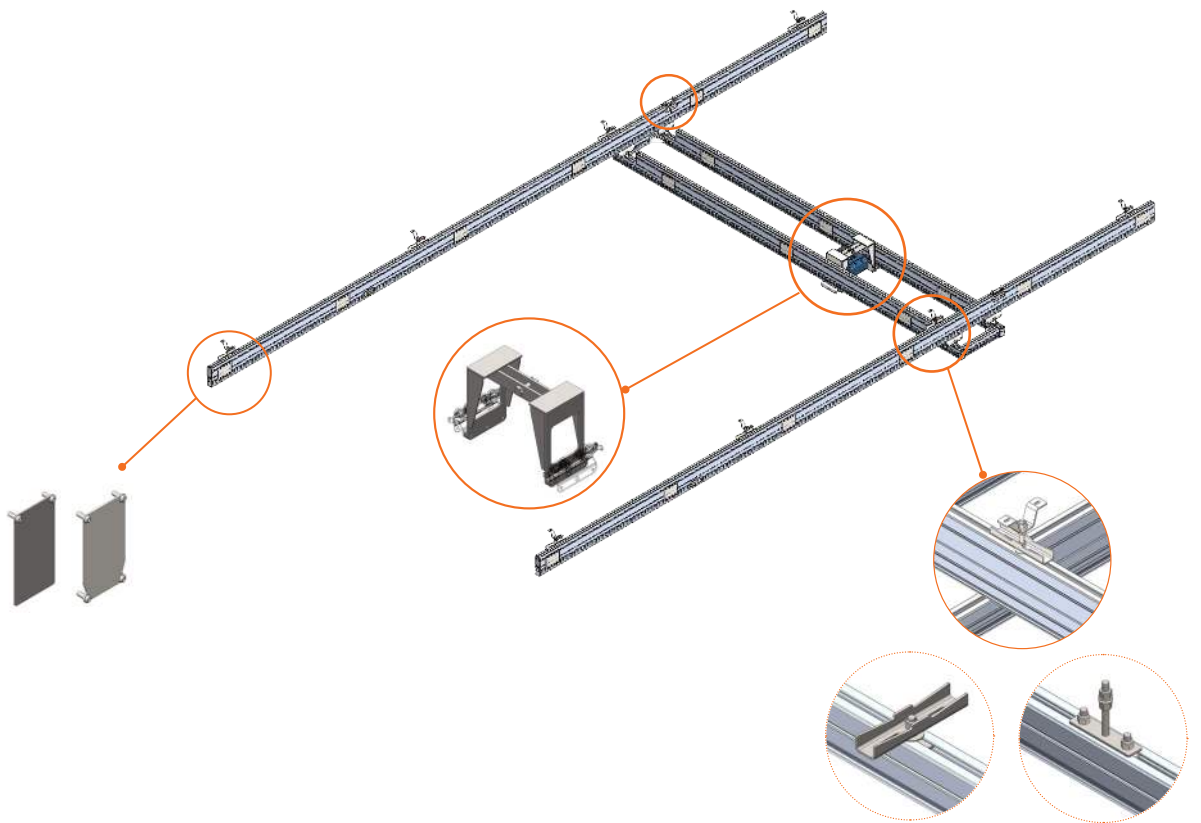

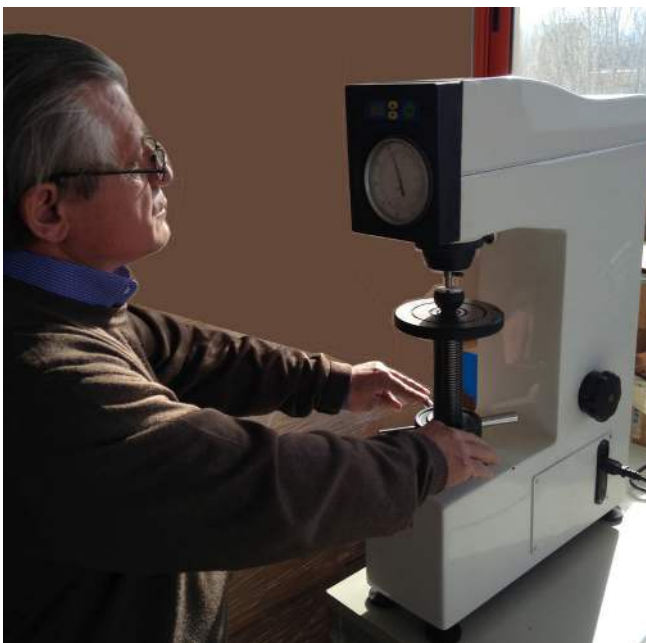
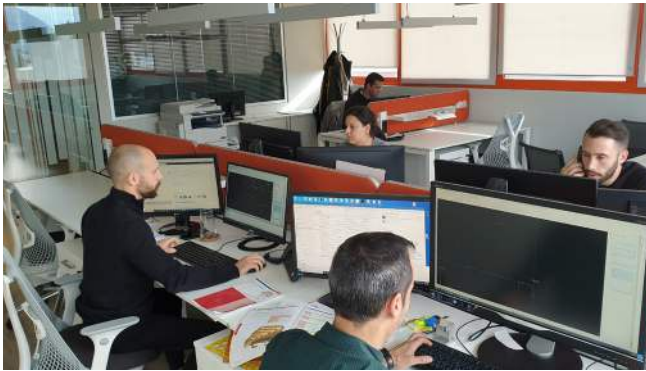

CERTIFICATE

ΕΓΓΥΙΑΣΤΗΡ ΗΛΕΚΤΡΟΝΙΚΗΣ

The Certification & Inspection Body EGA HELLAS S.A., certifies that

HELM HELLAS S.A.
82nd km N.R. ATHENS - KORINTHOS, GR 201 00 KORINTHOS

has established and applies a Quality Management System which is in conformance with:

EAOT EN ISO 9001:2015
(Quality Management System)

with the scope:

MANUFACTURING OF SLIDING DOOR FITTINGS & CONVEYOR SYSTEMS

Certificate Number:
GMS 3363/22

Date of Certification/
Certification Decision:
08 November 2021

Expiry Date:
08 November 2024

Initial Certification Date:
12 November 2009

FOR THE COMPANY
CHARALAMPOS GALATIANOS

EGA HELLAS S.A.
Palamioi Kaliterna 20, Chalandri 157 33  www.eqo.gr
 +30 210 44 34 0132  Fax: 400 210 44 32 715  eqo@eqo.gr | info@eqo.gr

The Certificate of Conformity is valid as long as the required level of surveillance quality. Its surveillance within 12 months from the initial certification date takes place once per year surveillance visits. At expiration of the initial certification decision cycle, and if it is subject to the applicable surveillance requirements, HELM HELLAS S.A. may extend applications.

 **LETRINA S.A.**
CERTIFICATION BODY

HELM HELLAS S.A.
82nd km NATIONAL ROAD ATHENS - KORINTHOS,
GR 201 00 KORINTHOS,
GREECE

Certificate Holder:

Scope: **DESIGN, PRODUCTION OF SLIDING DOOR FITTINGS AND CONVEYOR SYSTEMS**

ΠΙΣΤΟΠΟΙΗΤΙΚΟ - CERTIFICATE

  
I. Bertatos

