

F  
1

# Fall Arrest Systems

## Product Catalogue

Technical Information  
Component Specification



*NIKO ... Quality in Motion*

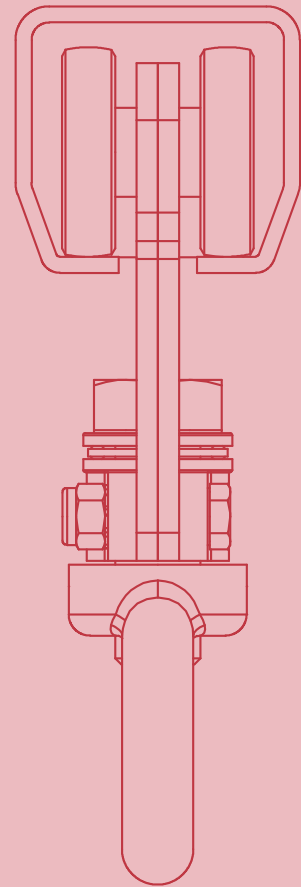

[www.niko.eu.com](http://www.niko.eu.com)  
[www.niko.co.uk](http://www.niko.co.uk)  
[www.nikotrack.com](http://www.nikotrack.com)  
[www.niko.world](http://www.niko.world)

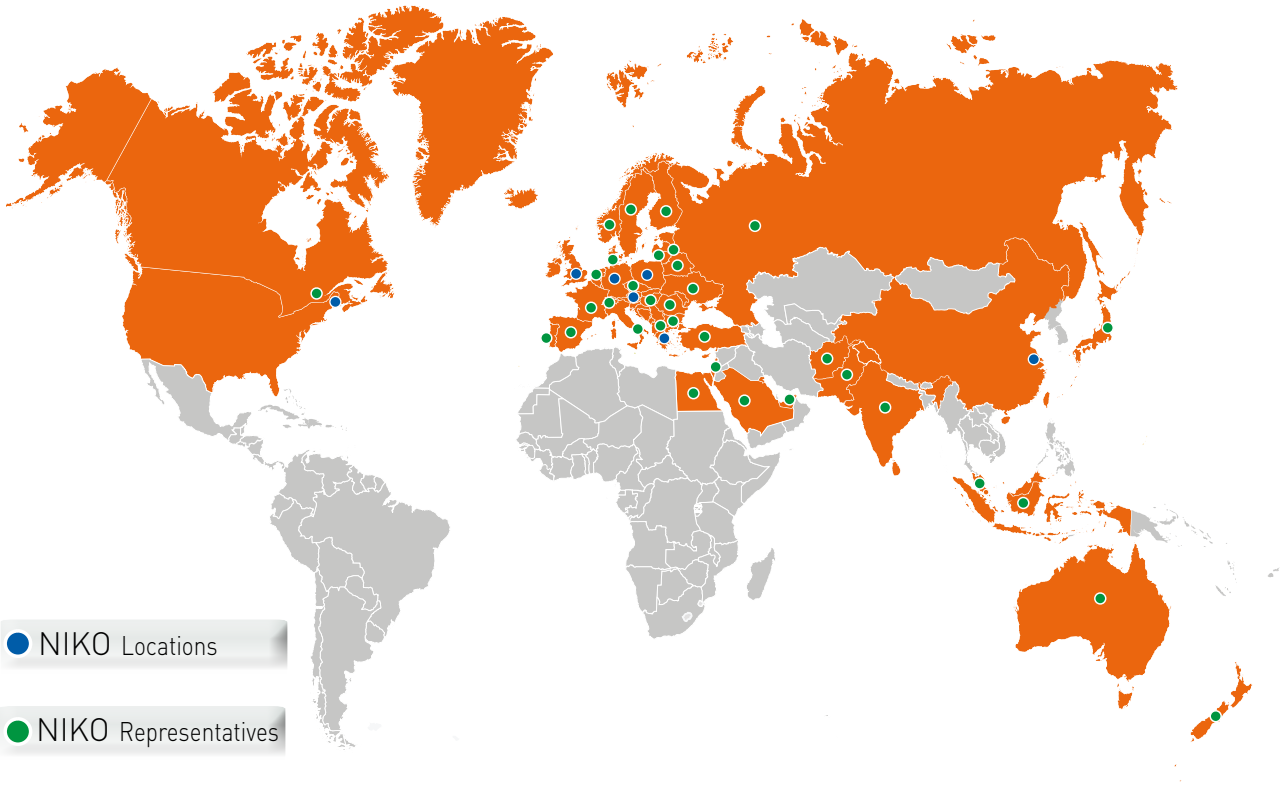

## Company Profile

Established in 1972, NIKO is focused on designing developing, producing and marketing high quality sliding door fittings and overhead conveyor systems at the right price. NIKO currently has a direct presence at seven locations (Greece, Germany, Austria, United Kingdom, Poland, China and U.S.A.), and indirectly through representatives and agents in most European countries, North Africa, Asia and Australia.

Our product range includes more than 2.000 different assemblies & components. Our team of highly qualified engineers are continually working to improve our current product portfolio & extend it according to market requirements.

NIKO enforces a continuous quality control program and is certified according to ISO:9001 and ISO:14001.



# Contents

Application photos	Page	4
Advantages of Niko Fall Arrest Track vs Taut Wire Systems	Page	6
Mounting points	Page	7-8
NIKO Track profiles & Track bend	Page	9
Support brackets & joints	Page	10-18
Track end stop	Page	18
Trolleys	Page	19
Index	Page	21

# Application Photos

Fall Arrest System



# NIKO fall arrest system – The economic solution tailored to your requirements, while safety is assured

NIKO FALL ARREST SYSTEM is a horizontal rigid track system which consists of a mobile anchorage device, allowing for a person or persons to move freely with safety in a monorail or in crane system without the need to disconnect from the system.

The small number of components required, ensure the easy installation of the system which should always be installed horizontally.

**The fall arrest system NIKO PSS 25-26-27 is to be used exclusively for the safety of hanging persons. The system does not replace personal safety harnesses (PPE – personal protective equipment).**

## NIKO FALL ARREST SYSTEMS, consist of :

- ✓ Rigid track profiles.
- ✓ Splice joints that connect the track profiles.
- ✓ Support brackets , for wall or ceiling mounting as well as mounting to a steel structure.
- ✓ Trolleys and carriage trolleys , fitted with 4 wheels .
- ✓ Track end stops which prevent the trolley exit from the track profiles.

**The components of NIKO FALL ARREST SYSTEMS comply with EN 795:2012 & CEN/TS 16415: 2013-D.**

## Applications

- Aircraft service and maintenance
- Safety track for high ropes course
- Coach service and maintenance
- Sky glide track for soft play areas
- Train service and maintenance

# Advantages of Niko Fall Arrest Track vs Taut Wire Systems

- ✓ There is less distance to fall with NIKO FALL ARREST SYSTEM and therefore less impact on the body.
- ✓ No bouncing effect that can cause injury on secondary falls.
- ✓ Multiple person systems are safer with NIKO FALL ARREST SYSTEM. One person falling on a taut wire fall arrest system can cause other users to fall.
- ✓ Following a fall the NIKO FALL ARREST SYSTEM can be re-used immediately after passing a visual inspection. Taut wire fall arrest systems need to be completely replaced.
- ✓ The tapered edge design of the NIKO FALL ARREST SYSTEM achieves very free running movement and eliminates snag effect.
- ✓ Its modular design means that the NIKO FALL ARREST SYSTEMS can be easily moved, added to and changed after installation.
- ✓ NIKO FALL ARREST SYSTEM offers solutions that enable operators to pass each other without detaching themselves from the system.
- ✓ No length limits to the distance of NIKO FALL ARREST SYSTEMS.

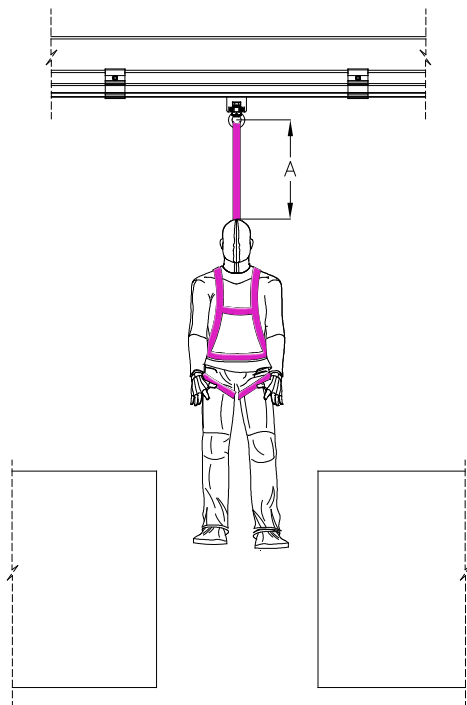

*Rigid track fall arrest system*

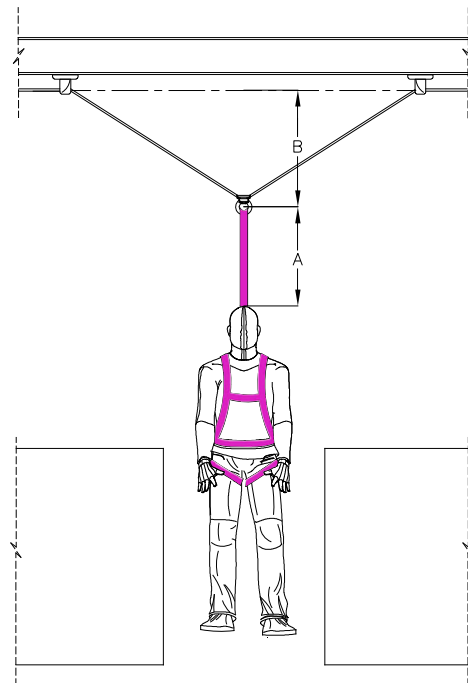

*Wire rope system*

A = DISTANCE REQUIRES TO ARREST  
B = WIRE ROPE SYSTEM DEFLECTION

# Mounting Points

For an effective installation of a NIKO FALL ARREST SYSTEM it is necessary to specify distance between the support brackets.

The permitted number of users in the system determines the maximum allowable distance between the support points of the track.

- a.) Determination of the maximum number of persons
- b.) Evaluation of the structural analysis of the supporting structure for the worst case scenario. In this case, all persons that are operating in the system cause at the same time a fall.
- c.) For the first person there must be calculated 12kn dynamic load effecting the system, for each additional person + 1kn.
- d.) For the maximum number of persons important is also an analysis of the rescue options.

## Example of line

- A = Overhanging end max. according to chart
- B = Suspension distance max. according to chart
- C = Distance to splice joint max. 500mm
- D = Middle of bend max. 1000mm

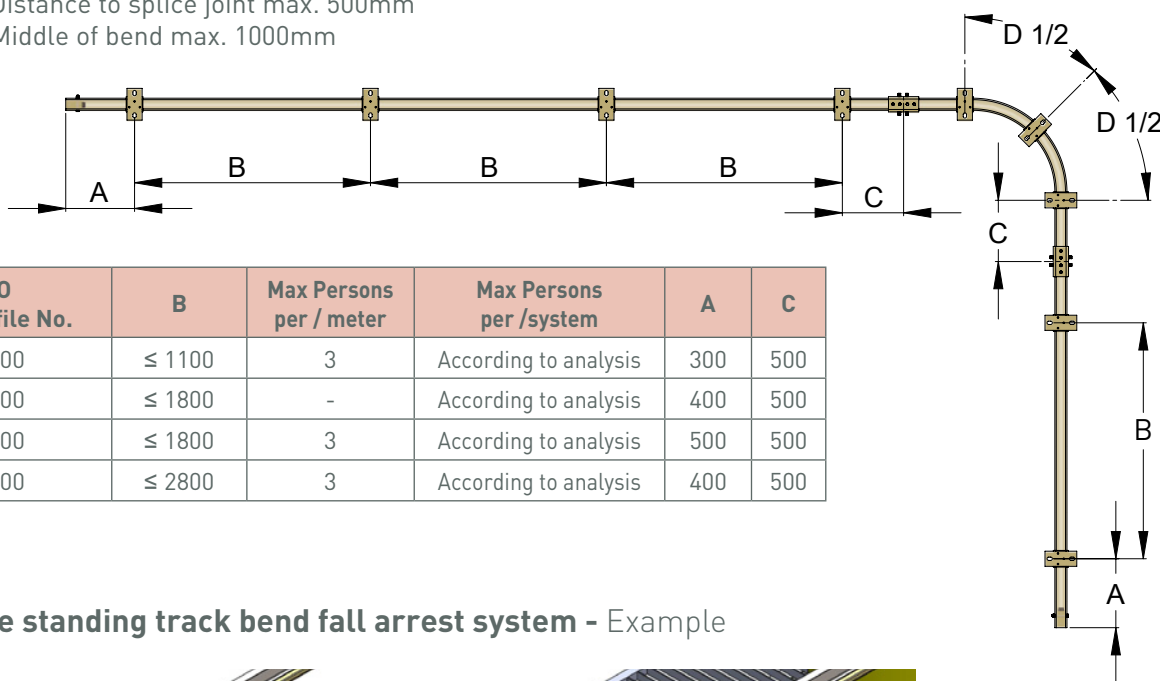

NIKO Profile No.	B	Max Persons per / meter	Max Persons per /system	A	C
25.000	≤ 1100	3	According to analysis	300	500
25.000	≤ 1800	-	According to analysis	400	500
26.000	≤ 1800	3	According to analysis	500	500
27.000	≤ 2800	3	According to analysis	400	500

Fall Arrest System

## Free standing track bend fall arrest system - Example

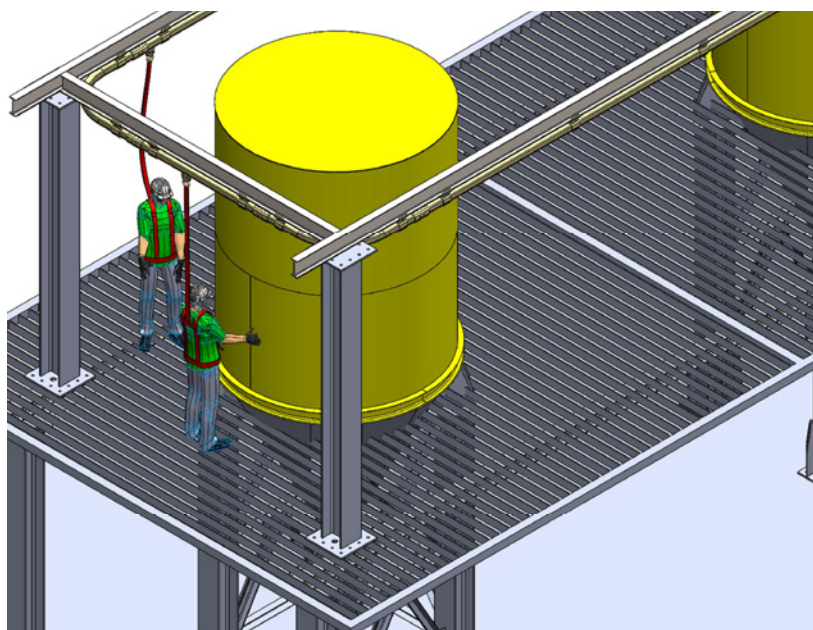

## Example of line with splice joint .B30

The suspension points are indicated on the below depicted line.  
 The given measurements are maximum distances.  
 For the connection of two tracks a splice joint .B30 is used.  
 The distance between the splice joint and the nearest suspension point must not exceed the distance C.

- A = Overhanging end max. according to chart
- B = Suspension distance max. according to chart
- C = Distance to splice joint .B30 max.mm

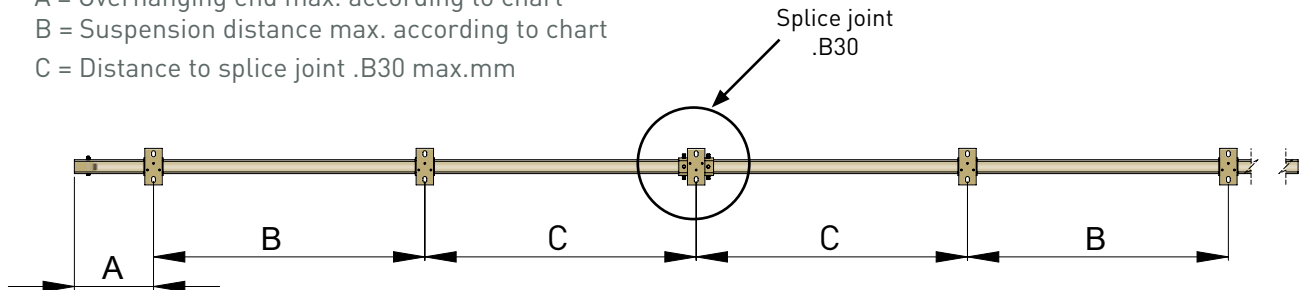

NIKO Profile No.	Suspensions/ max distances		
	B	A	C
25.000	1800	300	600
26.000	1800	400	800
27.000	2800	500	1200

## Monorail freestanding fall arrest system - Example

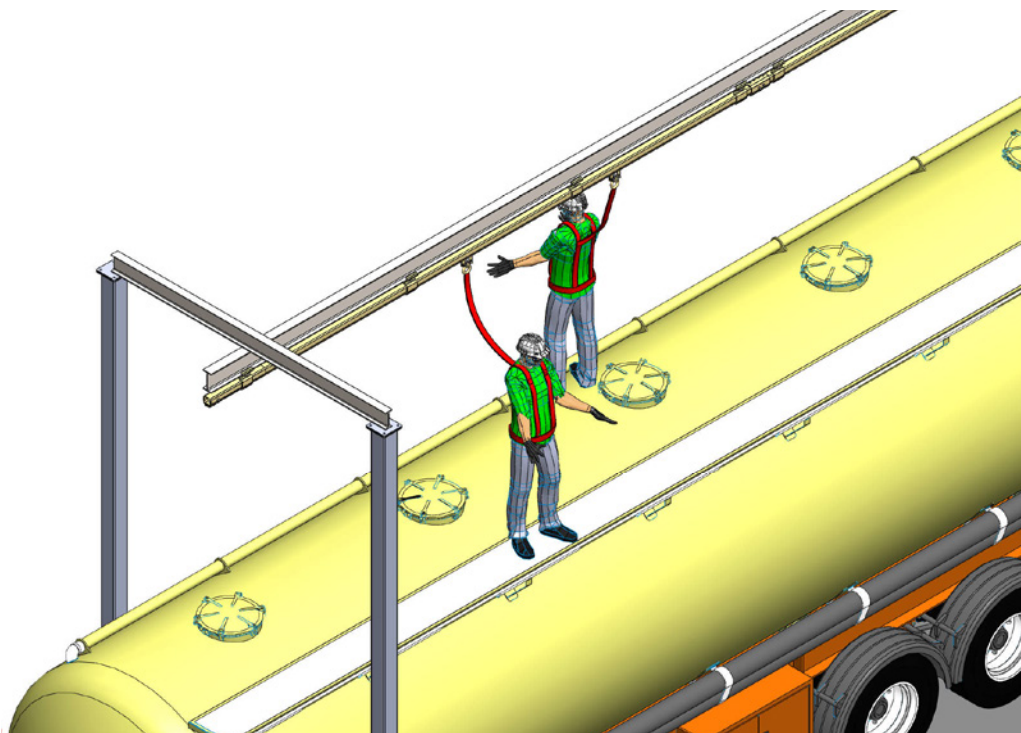



# NIKO Track Profiles

Our fall arrest product range of 3 Track profile sizes can accommodate up to 3 users. For the first person there must be calculated 12kn dynamic load effecting the system, for each additional person + 1kn. The NIKO enclosed track tapered design allows correct alignment of the trolleys and reduces the possibility of dust build up. This ensures the smooth running of the trolleys and the long life of the system.

NIKO Profile No.	Dimensions			
	h (mm)	b (mm)	d (mm)	s (mm)
25.000	60.00	65.00	18.00	3.60
26.000	75.00	80.00	22.00	4.50
27.000	110.00	90.00	25.00	6.50

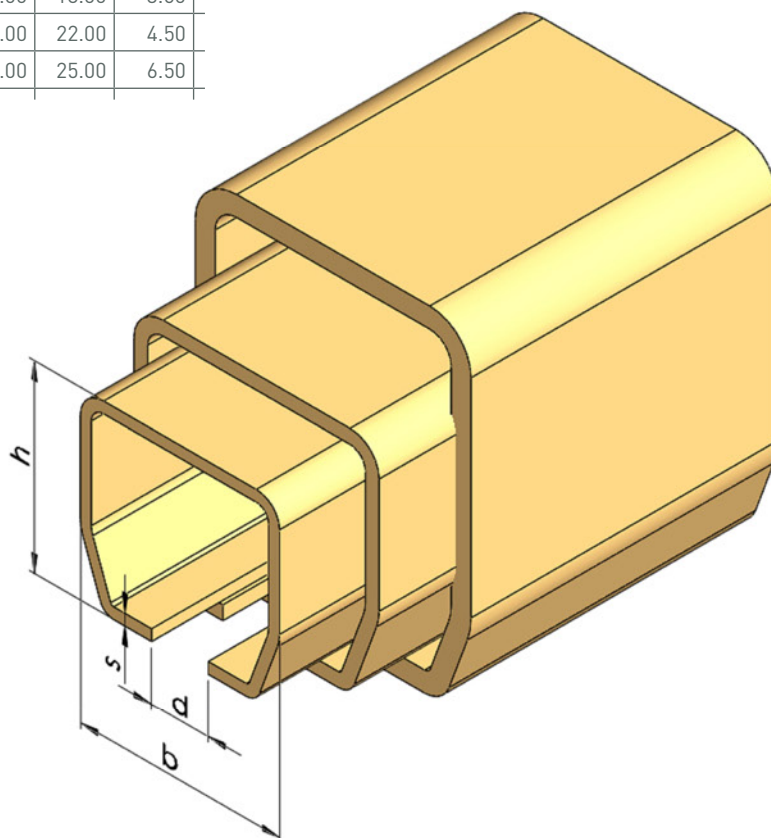
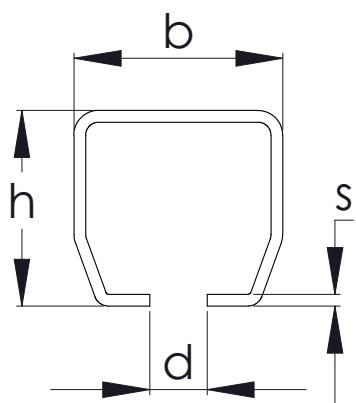

Fall Arrest System

## Track bend

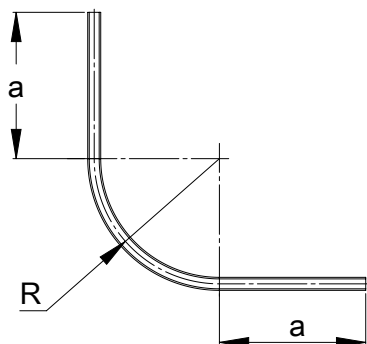

NIKO Profile No.	25.000	26.000	27.000
Track bend 90° No.	25.C06P	26.C08P	27.C10P
a (mm)	550±20	900±20	690±20
R (mm)	580±15	770±20	1035±20
L (mm)	2000	3000	3000

Other bend angles available upon request.

# Support bracket

**.B00P**

Zinc plated or plain, that can be used and adapted for specific applications where standard supports are unsuitable. CEN/TS16415:2013-D

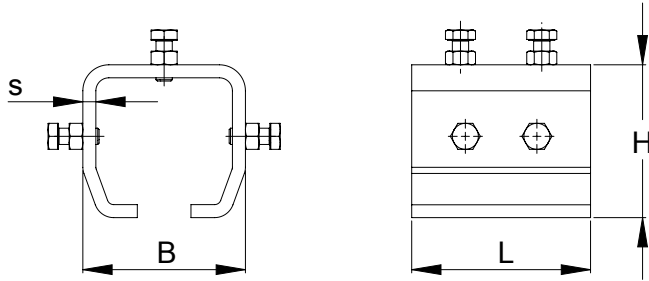
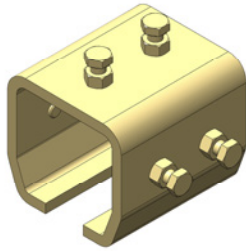

NIKO Profile No.	25.000	26.000	27.000
Part No.	25.B00P	26.B00P	27.B00P
L (mm)	90	110	120
H (mm)	75	94	133
B (mm)	81	100	116
s (mm)	6	8	10

Fall Arrest System

# Wall support bracket

**.B01P**

This kind of support is used for mounting the track directly on a wall or on other constructions with mounting bolts. CEN/TS16415:2013-D

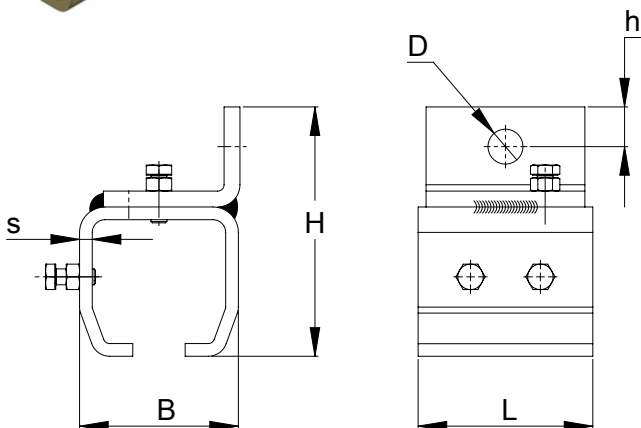
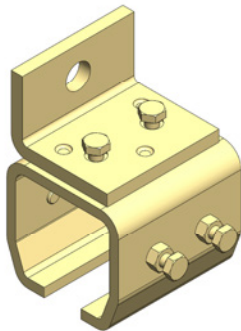

NIKO Profile No.	25.000	26.000	27.000
Part No.	25.B01P	26.B01P	27.B01P
L (mm)	90	110	120
H (mm)	123	156	205
B (mm)	81	100	116
s (mm)	6	8	10
D (mm)	17	22	26
h (mm)	18	24	27

# Ceiling support bracket

**.B02P**

This bracket is designed for bolting direct to overhead steelwork or ceiling.  
CEN/TS16415:2013-D

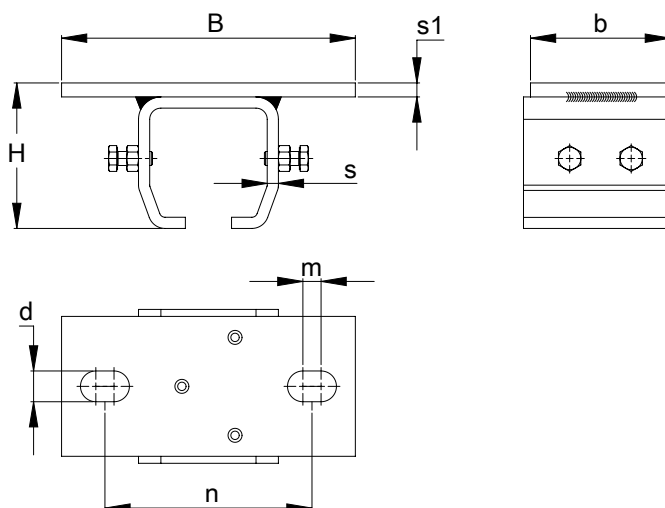
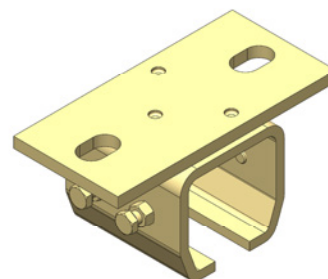

NIKO Profile No.	25.000	26.000	27.000
Part No.	25.B02P	26.B02P	27.B02P
B (mm)	171	210	260
H (mm)	81	104	145
b (mm)	80	100	120
s (mm)	6	8	10
d (mm)	17	22	22
n (mm)	124	148	178,5
m (mm)	10	12	23.5

Fall Arrest System

# Split support bracket (CEN/TS16415 Cert.)

**.B03P**

.B03 is generally used for variable height configurations.  
CEN/TS16415:2013-D

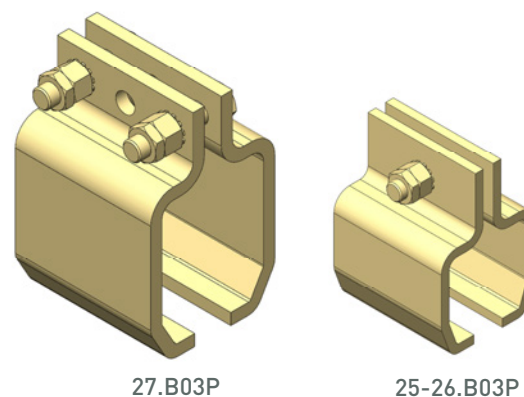
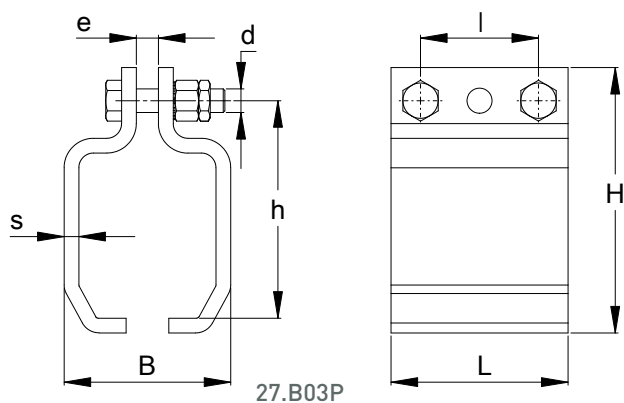

NIKO Profile No.	25.000	26.000	27.000
Part No.	25.B03P	26.B03P	27.B03P
B (mm)	77	96	110
H (mm)	131	150	180
h (mm)	94	112	148
L (mm)	90	110	120
s (mm)	6	8	10
d (mm)	M16	M16	M16
e (mm)	10	10	15
l (mm)	-	-	80

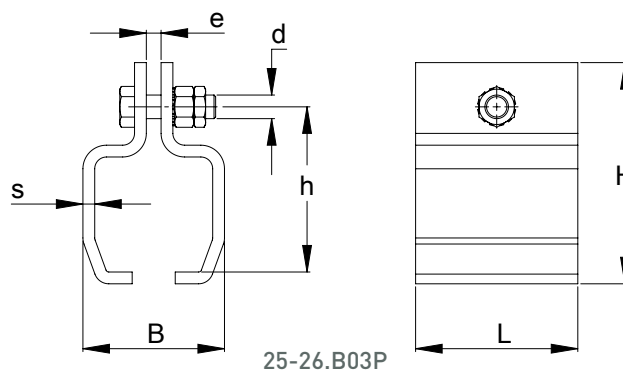

# Adjustable bracket with safety device

**.B04P**

.B04 allows the height adjustment of the rails and to correct any misalignments. CEN/TS16415:2013-D

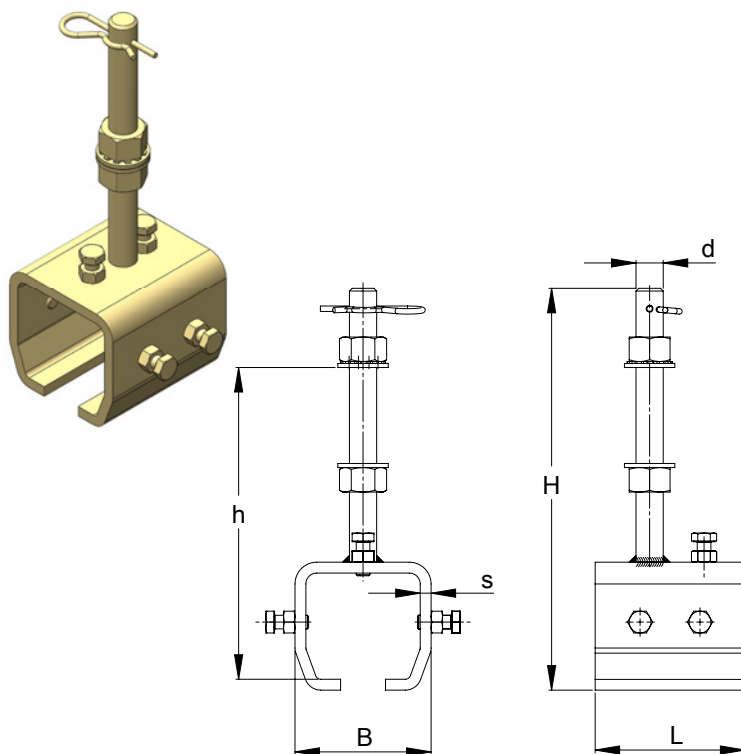

NIKO Profile No.	25.000	26.000	27.000
Part No.	25.B04P	26.B04P	27.B04P
B (mm)	81	100	116
H (mm)	215	295	348
h (mm)	170	250	295
L (mm)	90	110	120
s (mm)	6	8	10
d (mm)	M20	M20	M30

# Split suspension bracket

**.B10P/.B26P**

This bracket is used for mounting directly to the underside flange of a parallel I-beam. CEN/TS16415:2013-D

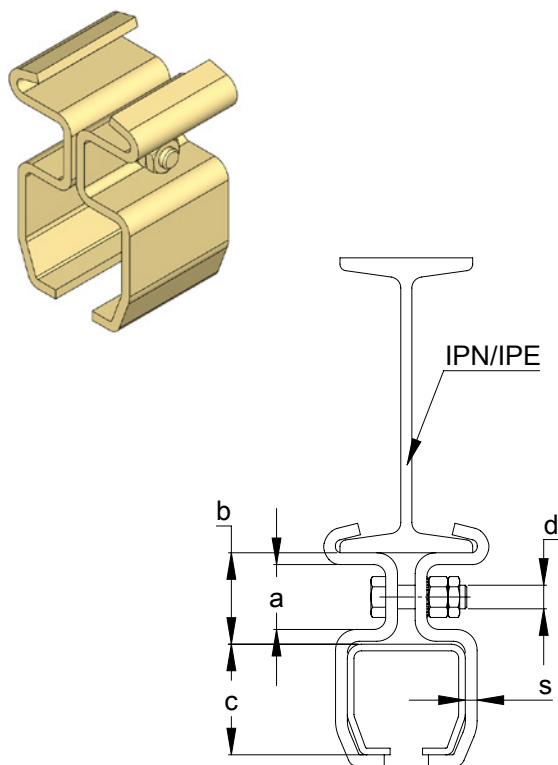

NIKO Profile No.	25.000	26.000	27.000
Dimension a in mm.	42	45	69
Dimension b in mm.	54	61	89
Dimension c in mm.	60	75	110
Dimension d in mm.	17 $\Phi$	17 $\Phi$	17 $\Phi$
s (mm)	6	8	10
Material	90x6	110x8	120x10
<b>Split Suspension Bracket Joist IPN DIN 1025</b>			
for IPN 100X50	25.B10P		
for IPN 120X58	25.B12P		
for IPN 140X66	25.B14P		
for IPN 160X74	25.B16P	26.B16P	
for IPN 180X82	25.B18P	26.B18P	
for IPN 200X90	25.B20P	26.B20P	27.B20P
for IPN 200X98	25.B22P	26.B22P	27.B22P
for IPN 240X106	25.B24P	26.B24P	27.B24P
for IPN 260X113	25.B26P	26.B26P	27.B26P

# Adjustable wall bracket

**.B05P**

.B05 is used in combination with the .B04 adjustable bracket and it usually mounts on the wall.  
CEN/TS16415:2013-D

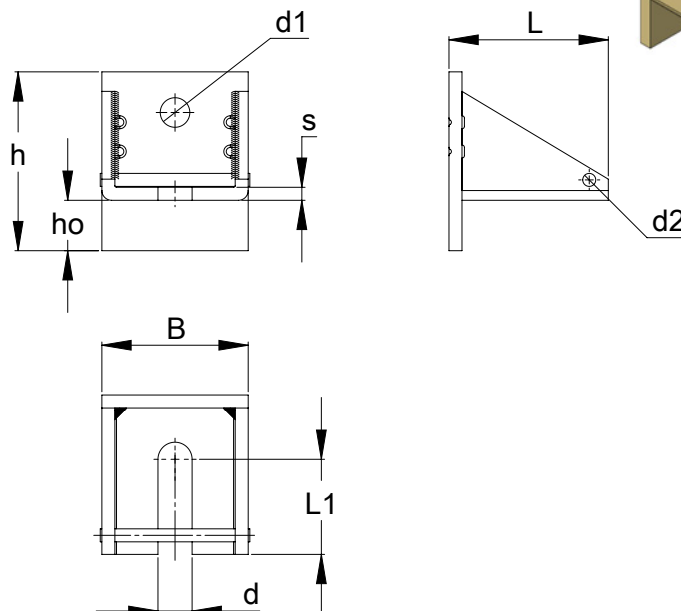
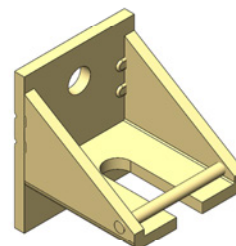

NIKO Profile No.	25/26.000
Art No.	26.B05P
L (mm)	98
B (mm)	90
h (mm)	110
ho (mm)	28
s (mm)	8
d (mm)	21
d1 (mm)	18
d2 (mm)	8
L1 (mm)	58

# Double adjustable wall bracket with safety device

**.B06P**

Double zinc plated steel wall bracket for twin tracks, for use with bracket .B04  
CEN/TS16415:2013-D

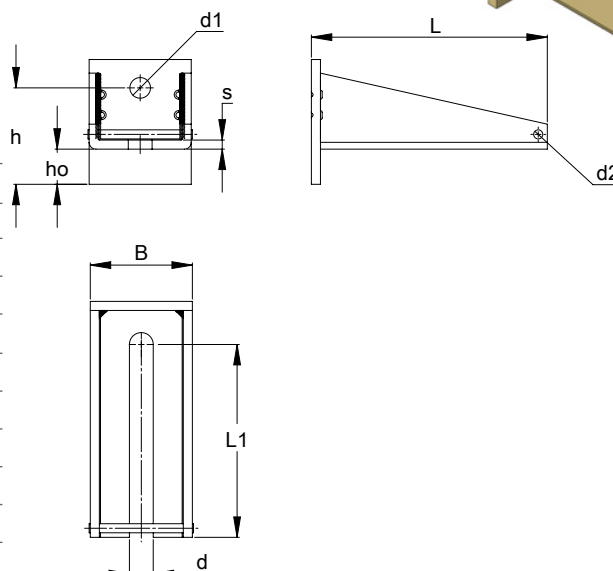
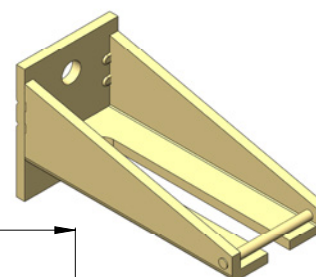

NIKO Profile No.	25.000 / 26.000	27.000
Part No.	26.B06P	27.B06P
L (mm)	208	208
B (mm)	90	90
h (mm)	84	80
ho (mm)	28	28
s (mm)	8	8
d (mm)	21	32
d1 (mm)	18	22
d2 (mm)	8	8
L1 (mm)	172	168

Fall Arrest System

# Double joist clamp (Parallel to the I-Beam)

**.B35P**

This bracket is used for mounting to the underside flange of a parallel I-beam. CEN/TS16415:2013-D

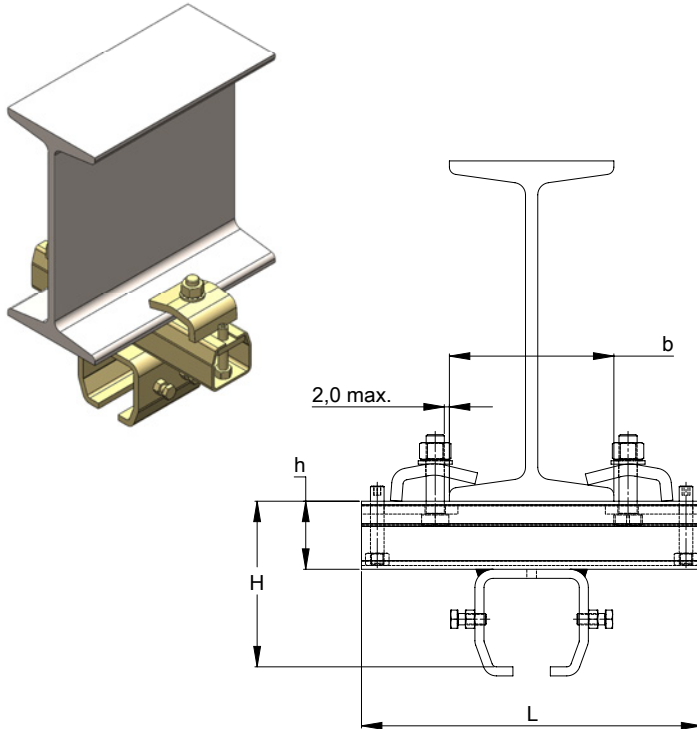

NIKO Profile No.	25.000	26.000	27.000
Part No.	25.B35P	26.B35P	27.B35P
L (mm)	300	300	330
H (mm)	129	146	199
h (mm)	60	60	75
b max (mm)	175	175	205

# Adjustable joist clamp (90° to the I-Beam)

**.B36P**

This bracket is used for mounting to the underside flange of a vertical I-beam. CEN/TS16415:2013-D

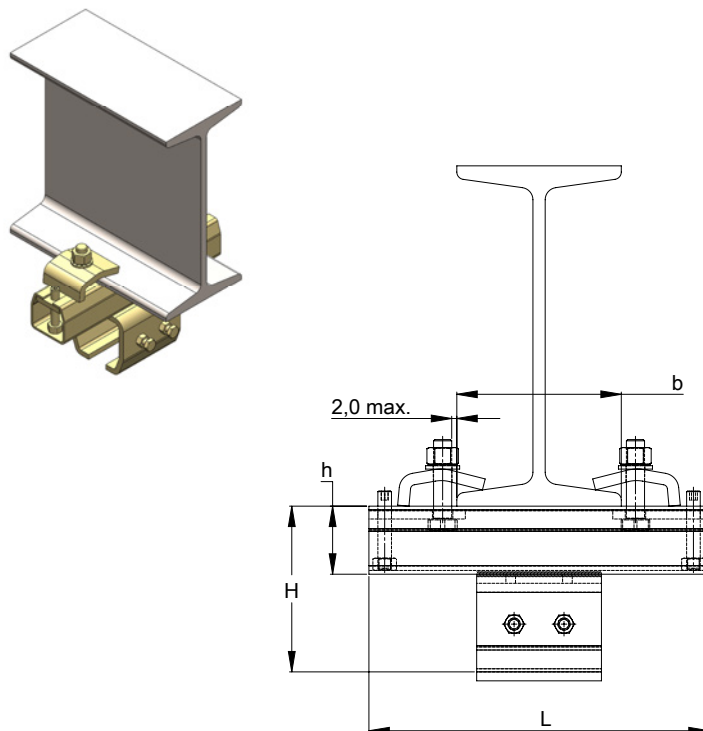

NIKO Profile No.	25.000	26.000	27.000
Part No.	25.B36P	26.B36P	27.B36P
L (mm)	300	300	330
H (mm)	129	146	199
h (mm)	60	60	75
b max (mm)	175	175	205

Fall Arrest System

## Adjustable joist clamp with splice joist (Parallel to I-Beam)

**.B71P**

This bracket is used to support and connect track profiles to the underside flange of a parallel I-beam.  
CEN/TS16415:2013-D

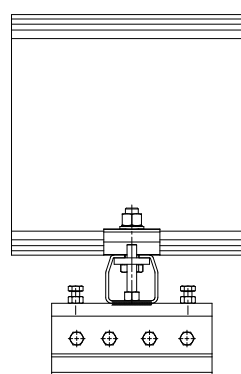
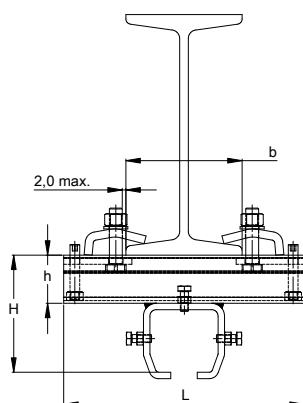
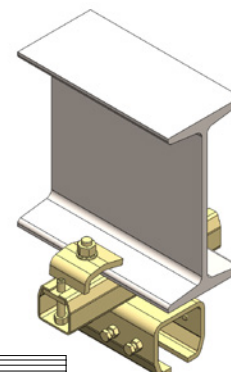

NIKO Profile No.	25.000	26.000	27.000
Part No.	25.B71P	26.B71P	27.B71P
L (mm)	300	300	330
H (mm)	129	146	199
h (mm)	60	60	75
b max (mm)	175	175	205

## Adjustable joist clamp with splice joist (90° to the I-Beam)

**.B72P**

This bracket is used to support and connect track profiles to the underside flange of a vertical I-beam.  
CEN/TS16415:2013-D

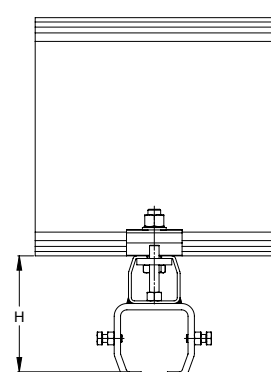
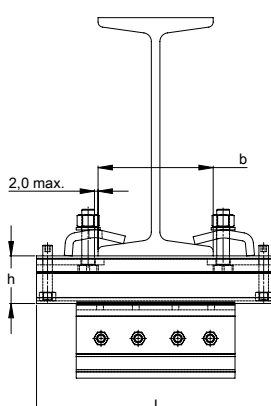
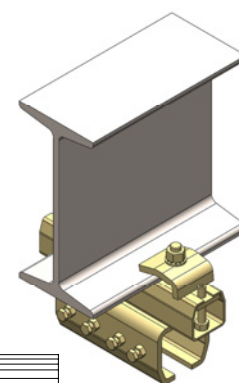

NIKO Profile No.	25.000	26.000	27.000
Part No.	25.B72P	26.B72P	27.B72P
L (mm)	300	300	330
H (mm)	129	146	199
h (mm)	60	60	75
b max (mm)	175	175	205

Fall Arrest System

# Splice joint for tracks

**.B49P**

The track sections are joined using the track joint by tightening the top screws first then aligning the profiles by means of the side screws. CEN/TS16415:2013-D

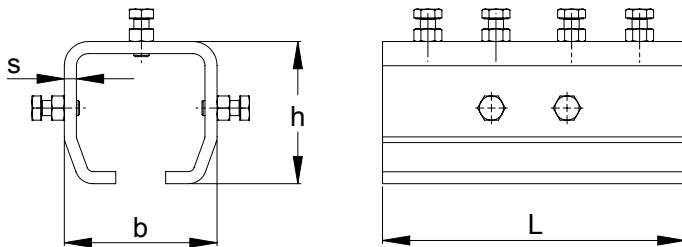
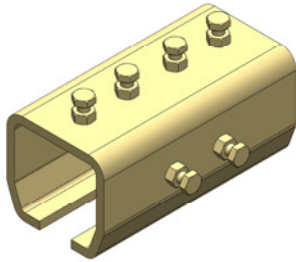

NIKO Profile No.	25.000	26.000	27.000
Part No.	25.B49P	26.B49P	27.B49P
L (mm)	180	200	250
h (mm)	75	94	133
b (mm)	81	100	116
s (mm)	6	8	10

Fall Arrest System

# Height adjustable support joint

**.B11P**

.B11 is a combination of a height adjustable bracket and a splice joint for mounting on adjustable wall brackets. CEN/TS16415:2013-D

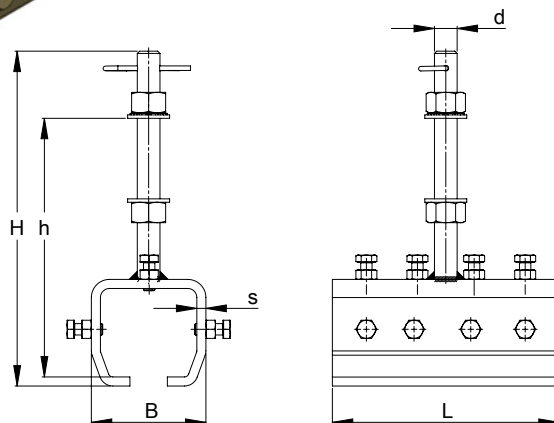
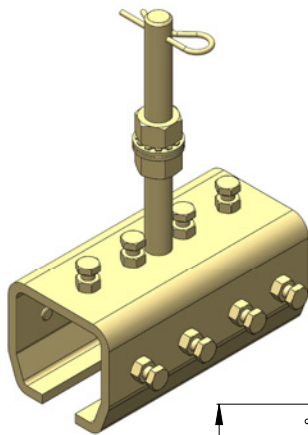

NIKO Profile No.	25.000	26.000	27.000
Art No.	25.B11P	26.B11P	27.B11P
B (mm)	81	100	116
H (mm)	215	295	348
h (mm)	170	250	295
L (mm)	180	200	250
s (mm)	6	8	10
d (mm)	M20	M20	M30



# Ceiling support joint

## .B30P

Zinc plated splice joint, for mounting direct to ceiling. Combination of a ceiling support and a splice joint.  
CEN/TS16415:2013-D

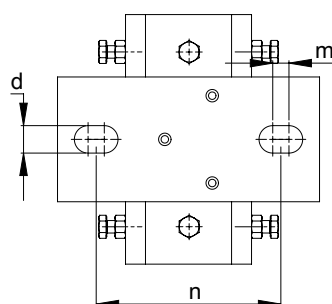
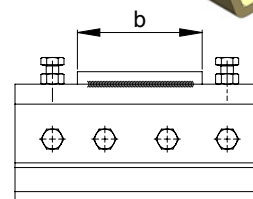
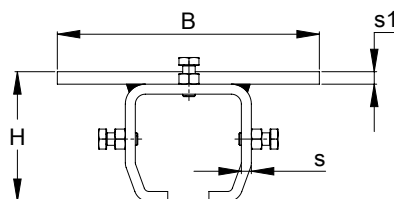
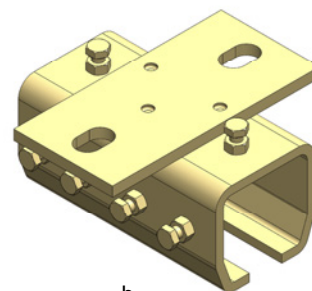

NIKO Profile No.	25.000	26.000	27.000
Art No.	25.B30P	26.B30P	27.B30P
B (mm)	171	210	260
H (mm)	81	104	145
b (mm)	80	100	120
s (mm)	6	8	10
d (mm)	17	22	22
n (mm)	124	148	178,5
m (mm)	10	12	23,5

# Scaffolding splice joint

## .B80P

This clamp is suitable for connecting and supporting the track profiles to existing scaffolding structure.  
CEN/TS16415:2013-D

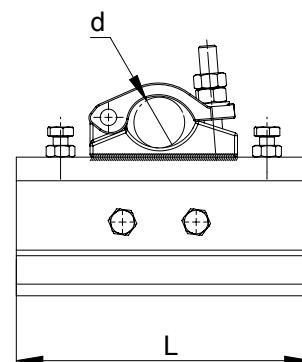
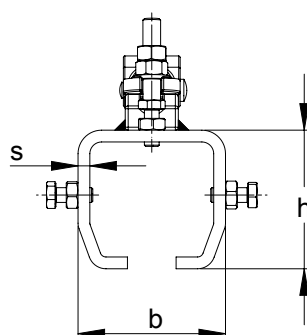
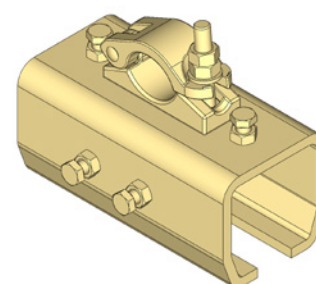

NIKO Profile No.	25.000	26.000	27.000
Adjustable joist No.	25.B80P	26.B80P	27.B80P
L (mm)	180	200	250
h (mm)	75	94	133
b (mm)	81	100	116
s (mm)	6	8	10
d MIN (mm)	40	40	40
d MAX (mm)	48,3	48,3	48,3

Fall Arrest System

# Scaffolding support bracket

## .B81P

This clamp is suitable for supporting the track profiles to existing scaffolding structure.  
CEN/TS16415:2013-D

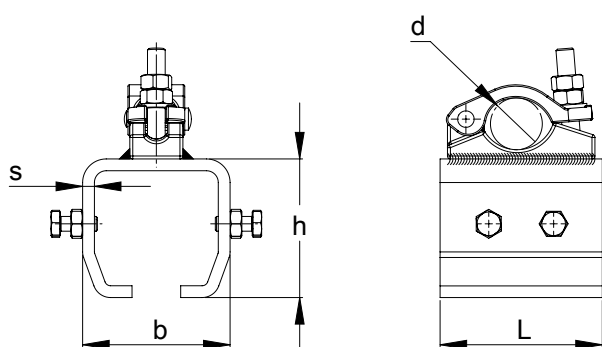
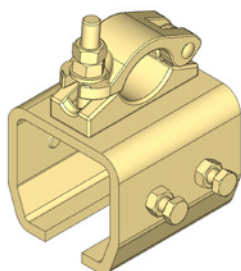

NIKO Profile No.	25.000	26.000	27.000
Adjustable joist No.	25.B81P	26.B81P	27.B81P
L (mm)	90	110	120
h (mm)	75	94	133
b (mm)	81	100	116
s (mm)	6	8	10
d MIN (mm)	40	40	40
d MAX (mm)	48,3	48,3	48,3

# Track end stop

## .X01P

At the end of the open profiles, an end stop with a rubber buffer must be positioned. Used in conjunction with a fixed cross belt. CEN/TS16415:2013-D

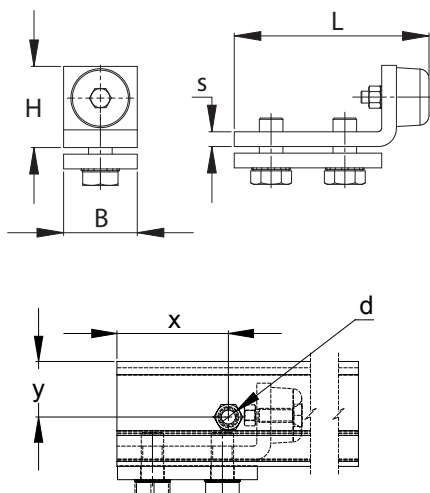
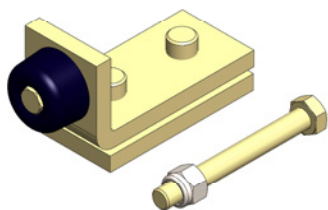

NIKO Profile No.	25.000	26.000	27.000
Part No.	25.X01P	26.X01P	27.X01P
L (mm)	120	130	130
H (mm)	47	60	60
B (mm)	40	50	50
s (mm)	8	10	10
x (mm)	85	85	85
y (mm)	30	30	60
d (screw dimensions in mm)	M8X80	M12X100	M16X120
Hole diameter for screw (mm)	8.5	13	17

## 4-Wheel trolley with hole

.T10P

This trolley is ideal for non standard self built applications. EN 795:2012-D CERT

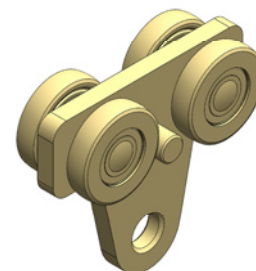

NIKO Profile No.	25.000	26.000	27.000
Part No.	25.T10P	26.T10P	27.T10P
L (mm)	120	145	210
H (mm)	62	70	180
h (mm)	60	75	110
b (mm)	65	80	90
D (mm)	18	22	26
e (mm)	20	24	35
d1 (mm)	12	17	20

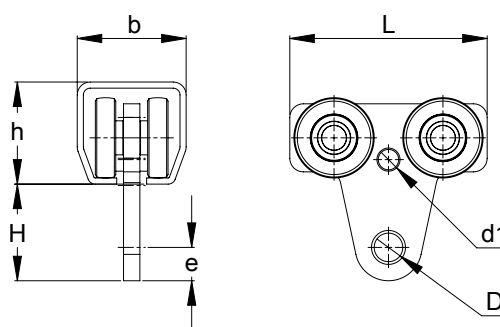

## 4-Wheel trolley with a rotating eye nut DIN 582

.T40P

4-wheel trolleys are suitable for hanging safety belts for fall arrest. EN 795:2012-D CERT

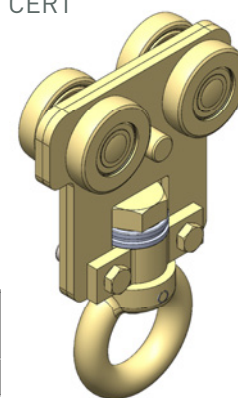

NIKO Profile No.	25.000	26.000	27.000
Part No.	25.T40P	26.T40P	27.T40P
L (mm)	110	150	200
H (mm)	93	123	163
h (mm)	60	75	110
b (mm)	65	80	90
D (mm)	72	90	108
d (mm)	40	50	60
d1 (mm)	12	17	20

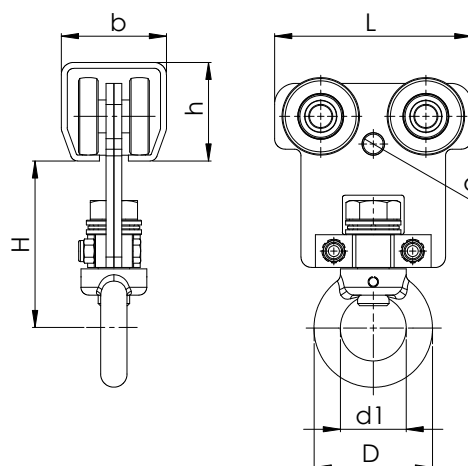



## NOTES

Lined area for notes

Fall Arrest System



## INDEX

Part No.	Page
25.000	9
26.000	9
27.000	9
25.B00P	10
25.B01P	10
25.B02P	11
25.B03P	11
25.B04P	12
25.B10P	12
25.B11P	16
25.B12P	12
25.B14P	12
25.B16P	12
25.B18P	12
25.B20P	12
25.B22P	12
25.B24P	12
25.B26P	12
25.B30P	17
25.B35P	14
25.B36P	14
25.B49P	16
25.B71P	15
25.B72P	15
25.B80P	17
25.B81P	18
25.C06P	9
25.T10P	19
25.T40P	19
25.X01P	18
26.B00P	10
26.B01P	10

Part No.	Page
26.B02P	11
26.B03P	11
26.B04P	12
26.B05P	13
26.B06P	13
26.B11P	16
26.B16P	12
26.B18P	12
26.B20P	12
26.B22P	12
26.B24P	12
26.B26P	12
26.B30P	17
26.B35P	14
26.B36P	14
26.B49P	16
26.B71P	15
26.B72P	15
26.B80P	17
26.B81P	18
26.C08P	9
26.T10P	19
26.T40P	19
26.X01P	18
27.B00P	10
27.B01P	10
27.B02P	11
27.B03P	11
27.B04P	12
27.B06P	13
27.B11P	16
27.B20P	12
27.B22P	12
27.B24P	12

Part No.	Page
27.B26P	12
27.B30P	17
27.B35P	14
27.B36P	14
27.B49P	16
27.B71P	15
27.B72P	15
27.B80P	17
27.B81P	18
27.C10P	9
27.T10P	19
27.T40P	19
27.X01P	18



ZERTIFIKAT | CERTIFICATE | CERTIFICAT | CERTIFICADO | СЕРТИФИКАТ | 證書 | 인증서

TÜV AUSTRIA SERVICES GMBH, vom österreichischen Bundesministerium für Wirtschaft, Familie und Jugend akkreditierte Prüf-, Inspektions- und Zertifizierungsstelle  
 TÜV AUSTRIA SERVICES GMBH, testing, inspection and certification body  
 accredited by the Austrian Federal Ministry of Economy, Family and Youth



## Zertifikat - Certificate

Nr.: TÜV-A-MHF/FT-14/FT04-026

<b>Hersteller:</b> Manufacturer:	<b>Helm Hellas S.A.</b> P.O.Box 209 GR-20100 Korinthos	<b>Bevollmächtigter:</b> Authorized deputy:	<b>NIKO Vertriebs GmbH</b> Hainfelderstraße 3 A-2564 Weissenbach
<b>Produkt:</b> Product:	<b>Persönliche Absturzschausrüstung – Anschlagleinrichtungen (EN 795 Klasse D)</b> Personal fall protection equipment – Anchor devices (EN 795 Class D)		
<b>Typ:</b> Type:	<b>NIKO PSS 25-26-27, Komponenten – siehe Anhang</b> NIKO PSS 25-26-27, components – see annex		
<b>Beschreibungen:</b> Description:	<b>Anschlagsystem zur Wand- oder Deckenbefestigung mit Schienenbogen und Weiche</b> Anchor device to be fastened an wall or ceiling with rail bend and double swivel switch		
<b>Prüfgrundlagen:</b> Tested according to:	<b>ÖNORM EN 795:2012 (ident EN 795:2012)</b> <b>ONR CEN/TS 16415:2013 (ident CEN/TS 16415:2013)</b> <b>ÖNORM EN 365:2004 (ident EN 365:2004)</b>		
<b>Bemerkungen:</b> Remarks:	<b>Siehe Anhang</b> See annex		

Hiermit bestätigt die TÜV AUSTRIA SERVICES GMBH als benannte Stelle (ID-Nr. 0408), dass das oben angeführte Produkt den grundlegenden Sicherheits-Anforderungen der Richtlinie entspricht. Grundlage dieses Zertifikates ist das zur Prüfung und Zertifizierung vorgelegte Prüfmuster und die technische Dokumentation.

Hereby TÜV AUSTRIA SERVICES GMBH certifies as notified body (ID No. 0408) that the above mentioned product meets the essential safety requirements of the Directive. The certificate is based on the test specimen and the technical documentation subjected to the test and the certification.

**TÜV-A-MHF/FÖT-1/04/FT04-026V2**

Vorgängerdokumente / former documents

**17.02.2011**

Datum / date

**10.11.2014**  
Datum  
date

**Ing. Karl Lueger**  
Prüfstelle  
examining department



**Dipl.-Ing. R. Schleifenlehner**  
Zertifizierungsstelle  
certifying department

**31.10.2019**  
Gültig bis  
valid till

Auszugsweise Vervielfältigung nur mit Genehmigung der TÜV AUSTRIA SERVICES GMBH gestattet  
 Duplication of this document in parts is subject to the approval by TÜV AUSTRIA SERVICES GMBH

TÜV AUSTRIA SERVICES GMBH  
 GB Maschinen-, Hebe- und Fördertechnik  
 A-1230 Wien, Deutschstraße 12  
<http://www.tuv.at>

Seite 1 von 1  
 FT14-079\_Zertifikat.docx

FB Fördertechnik  
 Tel.: +43 / 1 / 61091-6659  
 Fax: +43 / 1 / 61091-6650  
 e-mail: foet@tuv.at

Vervielfältigung nur mit Erlaubnis des TÜV AUSTRIA | The reproduction of this document is subject to the approval by TÜV AUSTRIA

Our quality control department is manned by experienced and highly skilled engineers. Our test lab is equipped with endurance test stands, tensile stress equipment, hardness test machines and other laboratory equipment. Virtual stress analysis is also performed during the developing phase of every component.

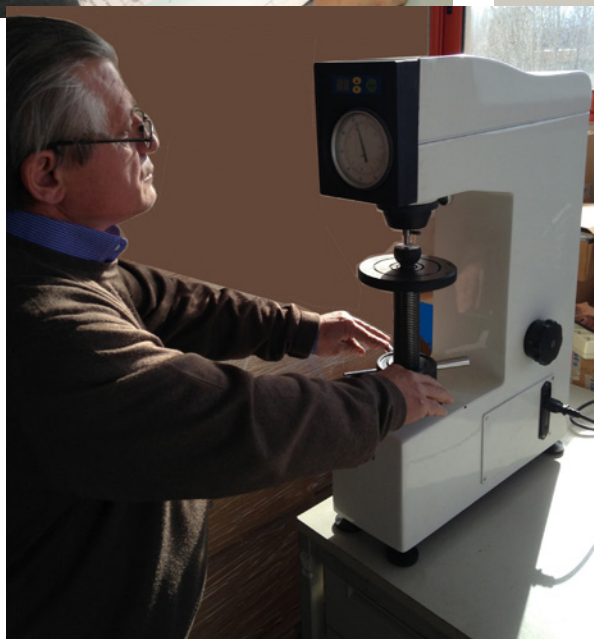
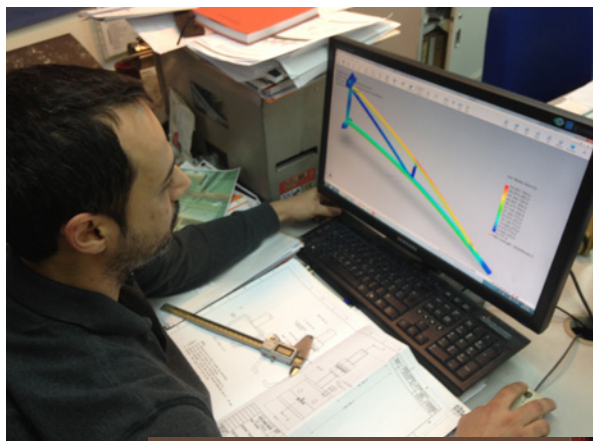

Fall Arrest System





## TRADITION IS PROGRESS PRESERVED, PROGRESS IS TRADITION CONTINUED

NIKO 1972 – 2017

A family business for 45 years, NIKO has been built on the foundations of Tradition and Progress, always heading towards a successful economic future.

## QUALITY IS THE RESULT OF ATTENTION TO DETAIL

Quality will always be a standard for us, our products, our staff and our partners.

## OUR VISION

We are an international company and our goal is to be market leaders in each of our business sectors.

## OUR VALUES

- ✓ We want to offer our customers the best quality at a reasonable price.
- ✓ We strive for continual improvement in our quality procedures – because we believe the company that doesn't move forward will be left behind.
- ✓ We respond to any demand on the market with the ongoing development of new products.
- ✓ We support our co-workers by ensuring they are highly motivated and well qualified.
- ✓ We want to expand into new sales markets to continue to win and satisfy customers.

**AUSTRIA-NIKO Vertriebs GmbH**  
 Hainfelder Straße 48  
 A - 2560 Berndorf  
 Tel. 0043 2672-21201  
 Fax 0043 2672-21201-13  
[office.at@niko.eu.com](mailto:office.at@niko.eu.com)  
[www.niko.world](http://www.niko.world)

**CHINA-NIKO TRADING (SHANGHAI) Co., Ltd**  
 Room 605, Building #13, No.354  
 Linghe Road, Pudong District,  
 P.R.China - 200120 Shanghai  
 Tel. 0086 139 1814 5645  
[info.cn@niko.eu.com](mailto:info.cn@niko.eu.com)

**GERMANY-NIKO Technik GmbH**  
 Robert-Bosch-Str. 14  
 DE - 42489 Wülfrath  
 Tel. 0049 (0) 2058 9093603  
 Fax 0049 (0) 2058 9093604  
[office.de@niko.eu.com](mailto:office.de@niko.eu.com)

**GREECE-Helm Hellas S.A.**  
 82<sup>nd</sup> Km Athens-Korinthos  
 P.O. Box 209  
 GR - 201 00 KORINTHOS  
 Tel. 0030 27410 76800  
 Fax 0030 27410 25368  
[info@niko.eu.com](mailto:info@niko.eu.com)

**POLAND- NIKO Polska**  
 Wojska Polskiego 65A  
 PL - Wielun 98-300  
 Tel. 0048 504 00 35 56  
[info.pl@niko.eu.com](mailto:info.pl@niko.eu.com)

**UNITED KINGDOM-NIKO Ltd**  
 Units 15-21, Insight Park  
 Welsh Road East, Southam  
 Warwickshire, CV47 1NE -UK  
 Tel. 0044 (0) 1926 813111  
 Fax 0044 (0) 1926 815599  
[Sales@niko.co.uk](mailto:Sales@niko.co.uk)  
[www.niko.co.uk](http://www.niko.co.uk)

**USA-NIKO Track**  
 300 Highpoint Ave  
 USA - Portsmouth, RI. 02871  
 Tel. 001 (0) 401 683 7525  
 Fax 001 (0) 401 293 3848  
[info@nikotrack.com](mailto:info@nikotrack.com)  
[www.nikotrack.com](http://www.nikotrack.com)

[www.niko.eu.com](http://www.niko.eu.com) [www.niko.co.uk](http://www.niko.co.uk) [www.nikotrack.com](http://www.nikotrack.com) [www.niko.world](http://www.niko.world)

Your **NIKO** agent will be happy to advise you:

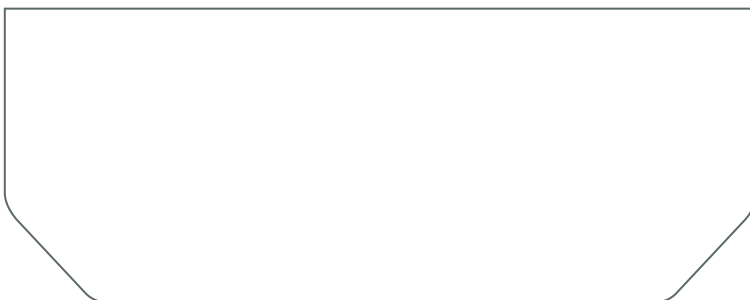

Complete **NIKO** product range:

- Light duty sliding door hardware
- Heavy duty sliding door hardware
- Conveyor systems
- Light cranes
- Cable trolleys, festoon systems & conductor bars
- Personal fall arrest systems (EN 795)
- Accessories for gates and doors