

Light Crane Systems

- Steel Cranes
- Stainless Steel Cranes 304/316
- Aluminium Cranes
- Light cranes and jib cranes variations

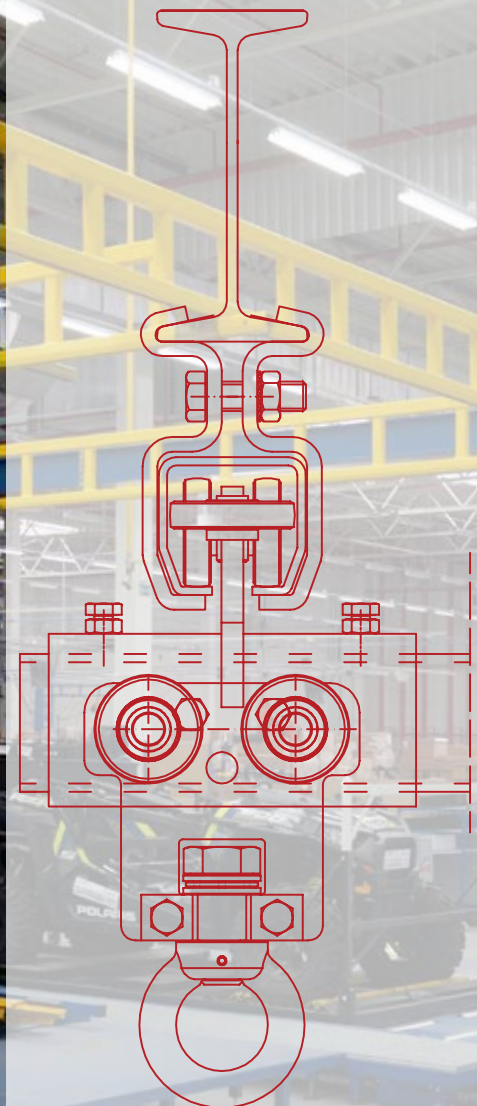

NIKO ... Quality in Motion



www.niko.eu.com

NIKO Light Cranes – A versatile and economic solution for loads up to 2.000 kg and 10 meter bridge length

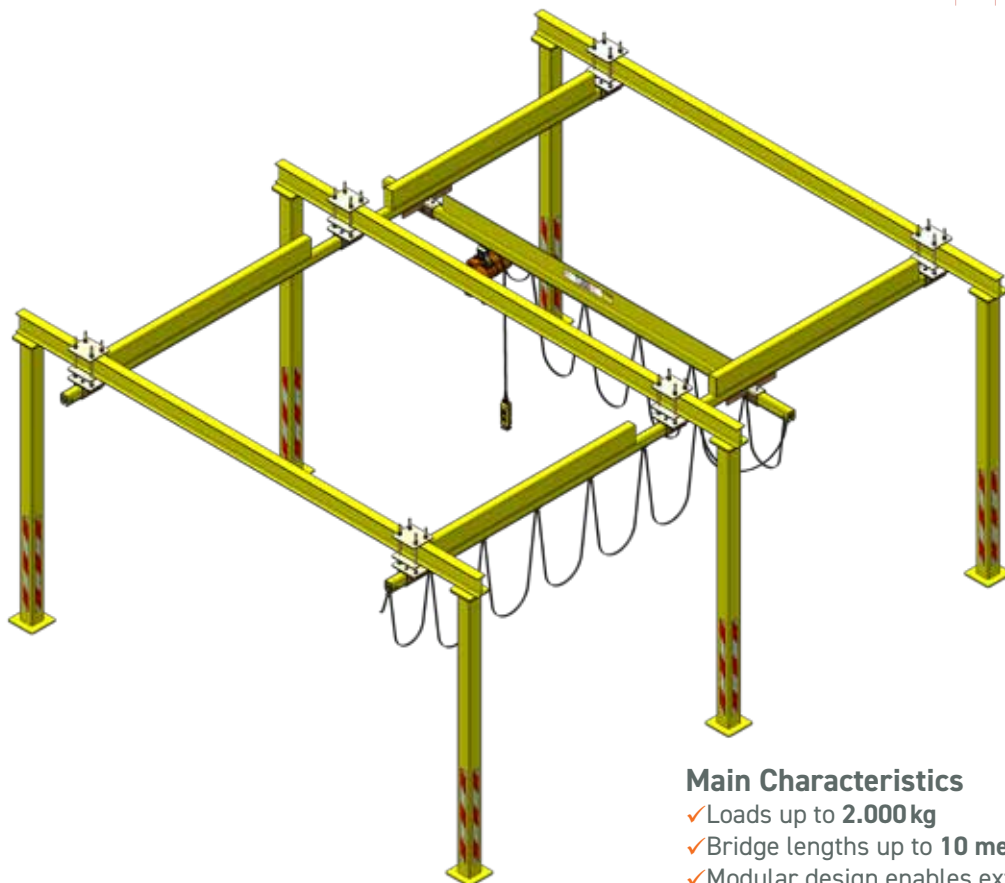

NIKO Light Crane System provides an ergonomic and cost effective solution to conventional overhead crane systems, particularly when there is a height and space restriction. Versatile and reliable overhead handling can be achieved for a variety of applications using the NIKO modular design. The robust design of our components and the high standards of manufacturing guarantees long life with little or no maintenance requirements.

Main Characteristics

- ✓ Loads up to **2.000 kg**
- ✓ Bridge lengths up to **10 meters**
- ✓ Modular design enables extension, modification and relocation
- ✓ Cost effective
- ✓ Easy to install using a variety of supporting brackets.
- ✓ Large range of mounting options
- ✓ Latching capability enables interconnection with existing or new conveyor or monorail systems
- ✓ Telescopic cantilever crane bridges and monorails
- ✓ Manual or electric travel
- ✓ Floor or ceiling mounted cranes.
- ✓ Gold/silver zinc or powder coated finish
- ✓ Competitive delivery time
- ✓ More flexible /bespoke solutions

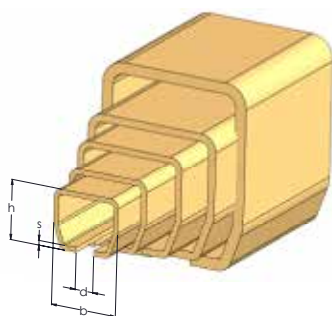

NIKO Profil No.	Dimensions			
	h (mm)	b (mm)	d (mm)	s (mm)
21.000	28,00	30,00	8,00	1,75
23.000	35,00	40,00	11,00	2,75
24.000	43,50	48,50	15,00	3,20
25.000	60,00	65,00	18,00	3,60
26.000	75,00	80,00	22,00	4,50
27.000	110,00	90,00	25,00	6,50

NIKO Track Profiles

The NIKO enclosed track tapered design ensures correct alignment of the trolleys and reduces the possibility of dust build up. This facilitates free and smooth running of the trolleys and a long life of the crane. NIKO light cranes require only 1-3% horizontal force to move the load being lifted. For use in aggressive environments we can also offer Niko Cranes in stainless steel grade 304 & 316.

Better headroom with NIKO rails

Light crane headroom

NIKO standard light cranes have considerably lower headroom than the competition. To create bigger spans reinforcements are added - these will fit up between the support steels and between the runways for the bridge. All manufacturers will offer a lower headroom solution, this is often double girder which is heavier, restricts travel and incurs more cost. NIKO can offer raised headroom systems which will allow you to mount the hoist within 100mm of the lowest obstruction.

Profile headroom Specification

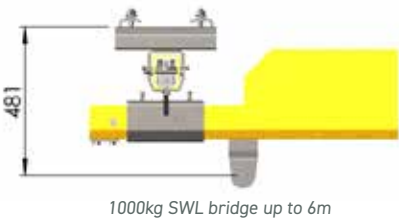
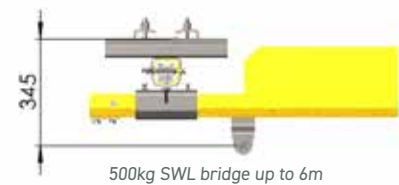
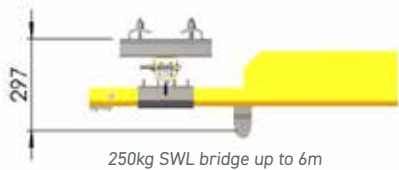

NIKO Steel Profiles

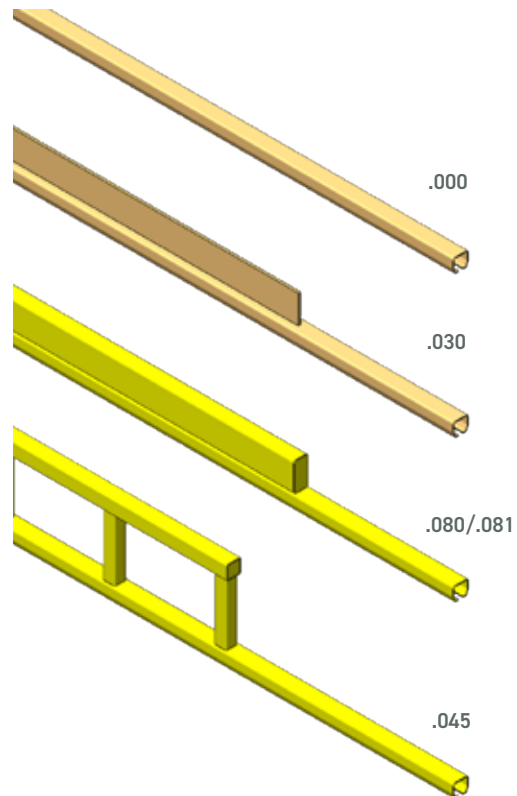

Runway Headroom

NIKO runways also save headroom over other manufacturers. Raised bridges will lift the hoist up but it does not change the runway heights. Where the headroom is extremely low, the more compact NIKO track can save the extra space. This can be enough to allow the user to walk underneath with no fear of banging their head. Welding the track or flat plate brackets can reduce the headroom even more.



Example of a 500kg crane runway or monorail

NIKO Stainless steel profile crane - Series 304/316

NIKO stainless steel light cranes are used in industries like pharmaceutical and fine chemical industries. They are also being applied in corrosive environments, or in areas that are frequently washed or disinfected (such as in food processing).

STAINLESS
STEEL
304

STAINLESS
STEEL
316

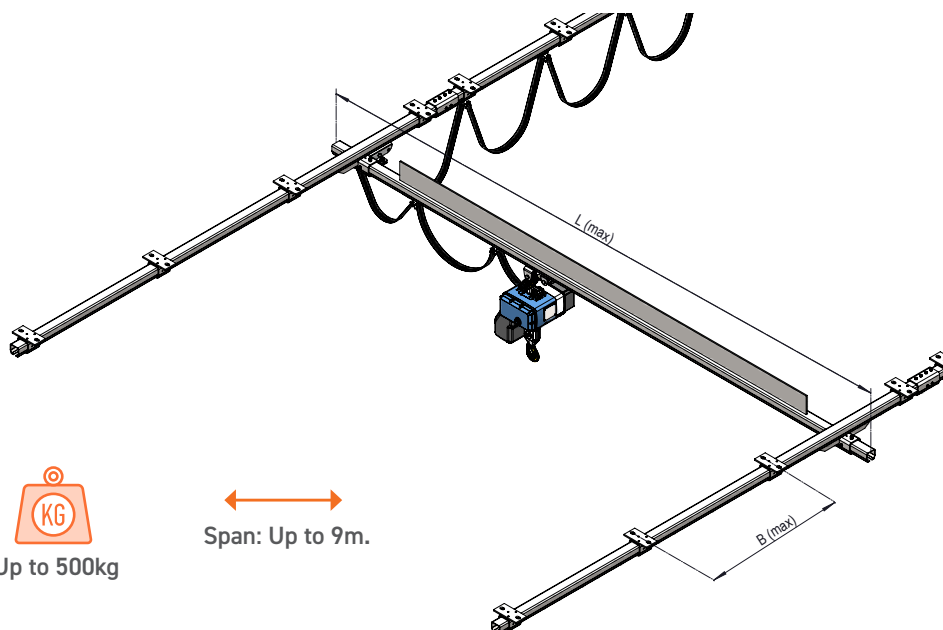

Up to 500kg



Span: Up to 9m.

NIKO Aluminium profile crane

The perfect alternative to every light material handling need!

The light weight and the robust design of our aluminium crane offer an easy installation and a weightless feel of the load during the movement. A big advantage of the NIKO aluminium system it can be stocked and no fabrication is required. The reinforced sections slot into the existing rail and are secured with bolts. Rails can be cut the required length and the end caps can still be fitted.

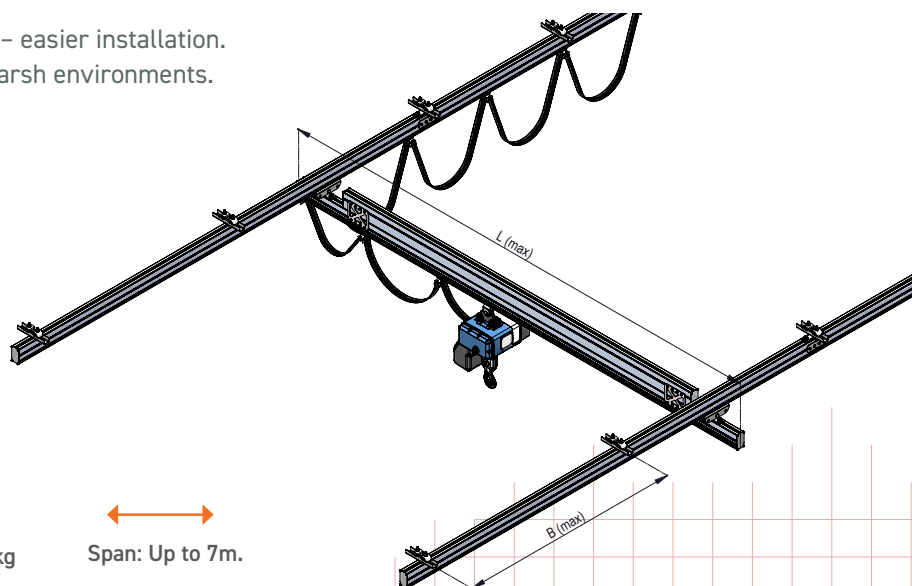
- ✓ Lower noise level during operation.
- ✓ High corrosion resistance
- ✓ Low dead weight of profiles – easier installation.
- ✓ Suitable for installation in harsh environments.



250-1000kg

Span: Up to 7m.

NIKO Light Cranes variations

1. A-frame mobile gantries



- ✓ Not fixed to one application, the A-frame can be moved to different locations.
- ✓ Can be used when there is no space for a permanent structure.
- ✓ Fixed or Mobile.
- ✓ I-beam or Profile.
- ✓ Height to under beam 1000-4000mm.
- ✓ Hoist travel: Manual, Geared, Electric.
- ✓ Nylon or Rubber tyre wheels.
- ✓ Material: Steel / Stainless steel.



10-2.000kg



Span: 1-6m.



Manual or
electric lifting

NIKO Light Cranes variations

2. I-Beam Cranes

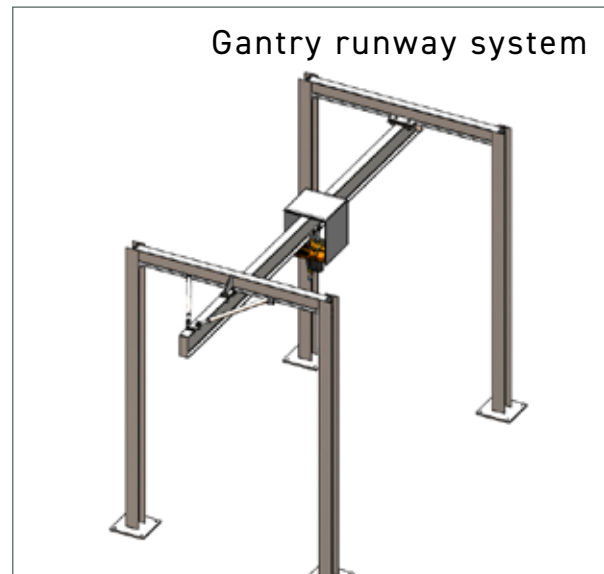
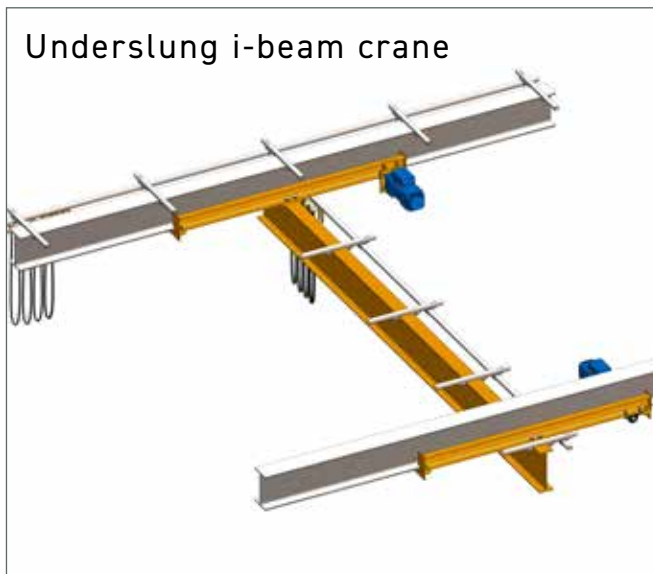
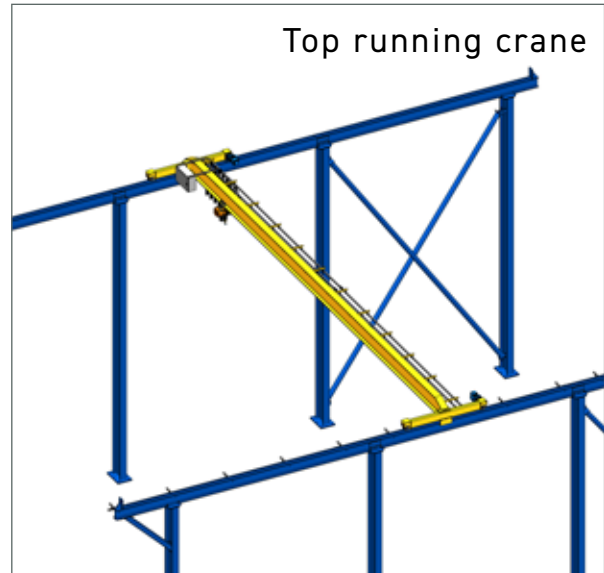
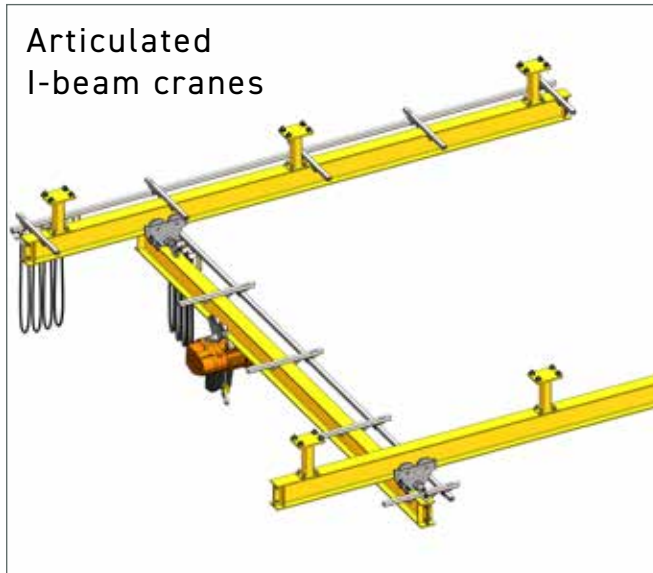

- ✓ Overhead travelling cranes can move larger loads with a great deal of control.
- ✓ Geared travel cranes can move larger loads when a power supply is not available and the load is too heavy for a manual system.
- ✓ Indoor or outdoor use.
- ✓ Freestanding or ceiling mount options.
- ✓ Yellow powder coat finish / galvanised.
- ✓ All powered end carriages are inverter driven.
- ✓ Radio and pendant control available.



250-2.000kg



Spans 2-10m.



Manual or
electric travel

Jib Crane variations

Overbraced (OB) NIKO Profile Jib cranes

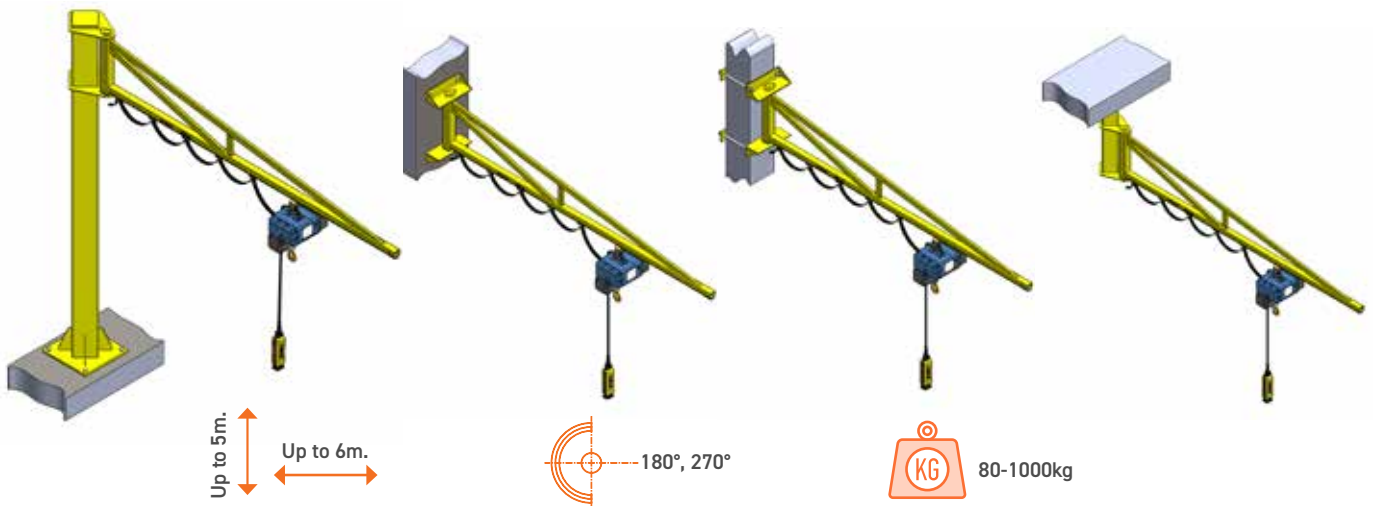

Under-braced (UB) I-beam jib cranes

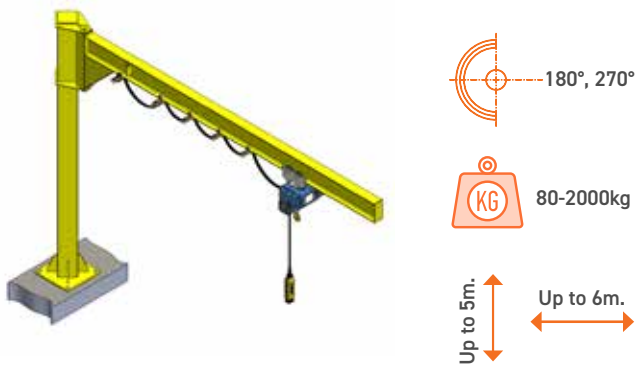

Over-braced (OB) I-beam jib cranes

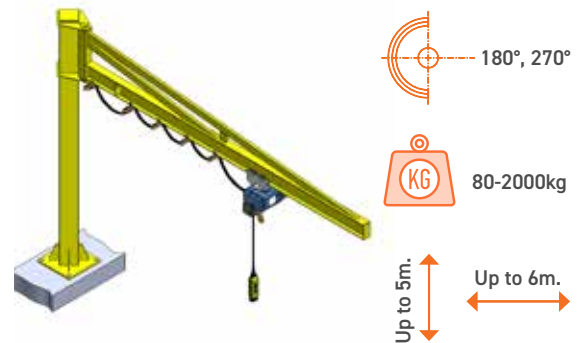

Articulated jib cranes



Aluminium Profile Jib cranes

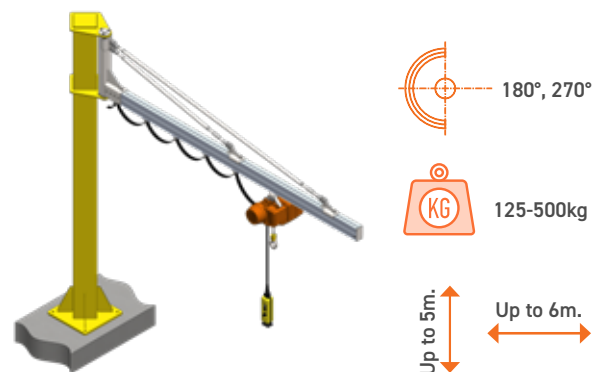

Advantages

- ✓ Made to order, no costs for excess steel or cutting.
- ✓ Free and easy to operate.
- ✓ Low maintenance.
- ✓ Lubrication-free bearings used on majority of jib arms.
- ✓ Base fabricated directly to pillar and therefore expensive foundation frames are not required.

Our jib cranes are provided with the compatible manual or electric hoist upon request.

NIKO Scaffolding Runway System



- ✓ The profile design is light, fast and simple to install.
- ✓ Permanent or temporary installation.
- ✓ Lighter than traditional I-beam solutions.
- ✓ Ergonomic material handling with the free running profile tracking.
- ✓ Reduces costs on a construction site; can perform tasks which usually require a tower crane.
- ✓ Due to the modular nature of the system it can be extended or shortened with off the shelf components.
- ✓ Can be used in tight areas which are not normally accessible with a standard crane.
- ✓ Cantilever off scaffolding to enable goods to be picked up from ground level.



0-2.000kg



Supplied in 3m. length



Manual or electric travel

Powered or Manual travel:

Manual travel should always be the default for light crane systems, this takes advantages of the smooth free running characteristics. Differences between manual and powered cranes:

- Manual cranes will move as fast as the user.
- Smooth operations, no abrupt braking or ramp up or down on inverters
- Manual systems are a cheaper investment
- Less chance of downtime with fewer electrical parts
- Lower maintenance costs
- Less chance of collision as the user walks with the load

When to use powered travel:

- Moving heavier loads over 1000kg
- Moving larger loads where the load is difficult to maneuver
- When loads needs to be lifting over obstruction or out of reach of the user

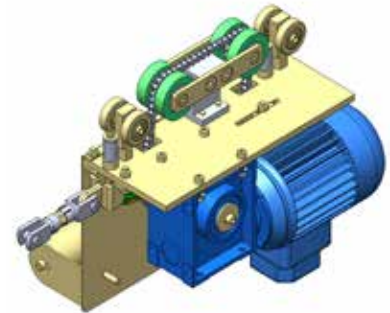







NIKO Bearings Trolleys

NIKO End carriages and trolleys can be easily equipped with a variety of bearings options, from low temperatures to high, heavy duty polyamide to stainless steel and special environments.



**PLN
Bearings**

- ✓ smoother running
- ✓ more silent

Low temperature bearings (special grease) for operating temperatures from -50°C to 80°C	TL.	
High temperature bearings (special grease) for operating temperatures from -40°C to 260°C	TH.	
Nylon tyred bearings	PL.	
Heavy duty polyamide tyred bearings	PLN.	
Ammonia resistant bearings (special grease) for operating temperatures from -20°C to 130°C	AM.	
Stainless steel bearings for operating temperatures from -20°C to 80°C	IN.	
Phosphor bronze tyred bearing	PB.	

Festoon Systems and Conductor bars

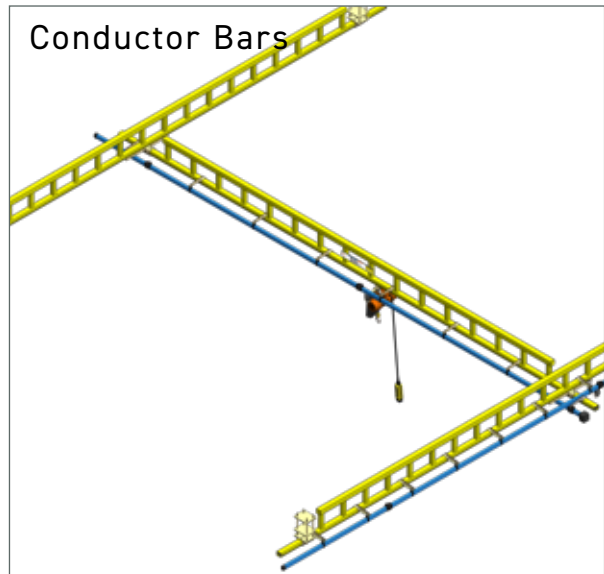
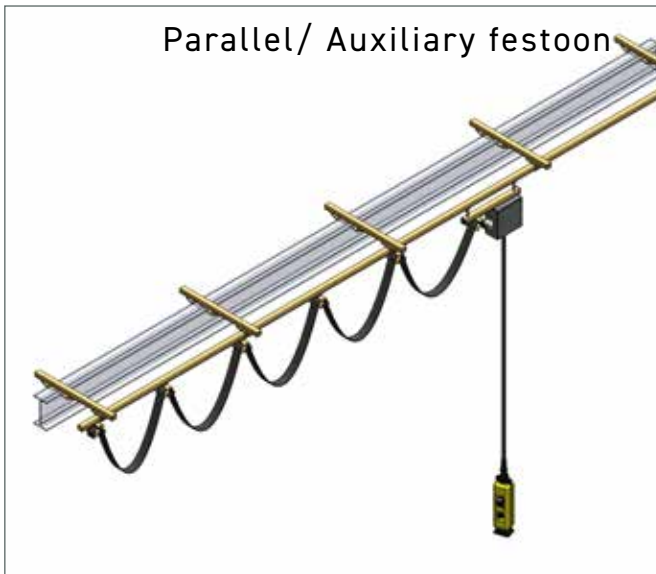
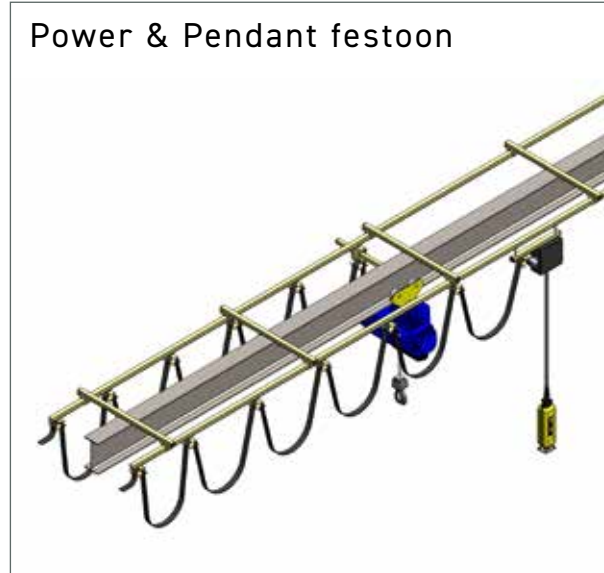
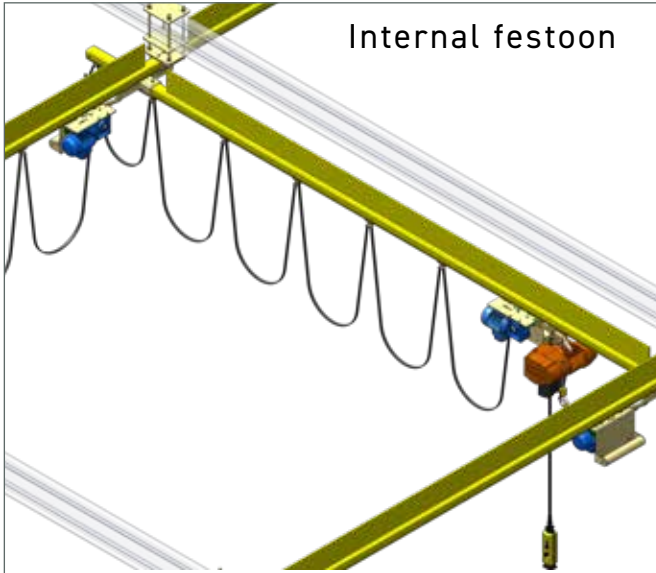

NIKO Festoon Systems are:

- ✓ Simple to install.
- ✓ More robust than catenary taut wire cable festoon system.
- ✓ Free running in operation.
- ✓ High safety factor.
- ✓ Low maintenance.
- ✓ The NIKO range comprises of 5 track systems to suit varying weights and quantities of cable or hose.

Conductor Bars:

- ✓ Unhindered travel length – no cable bunch up at feed end.
- ✓ Ability to feed more than 2 machines at the same time.
- ✓ No limit to the length of the system.
- ✓ Very quick and easy to install.
- ✓ Can be fed from an end or at any joint.
- ✓ Ideal for space constrained areas due to compact housing size.

NIKO Light Cranes options

1. Telescopic cantilever crane and monorail



- ✓ Cover a wider area than the supporting structure permits.
- ✓ Telescopic cantilever cranes are also possible, which are often installed in containers, trucks and vans. This facilitates overhead lifting and loading from outside and into the vehicle.

NIKO Light Cranes options

2. NIKO interlocks (Latching devices)

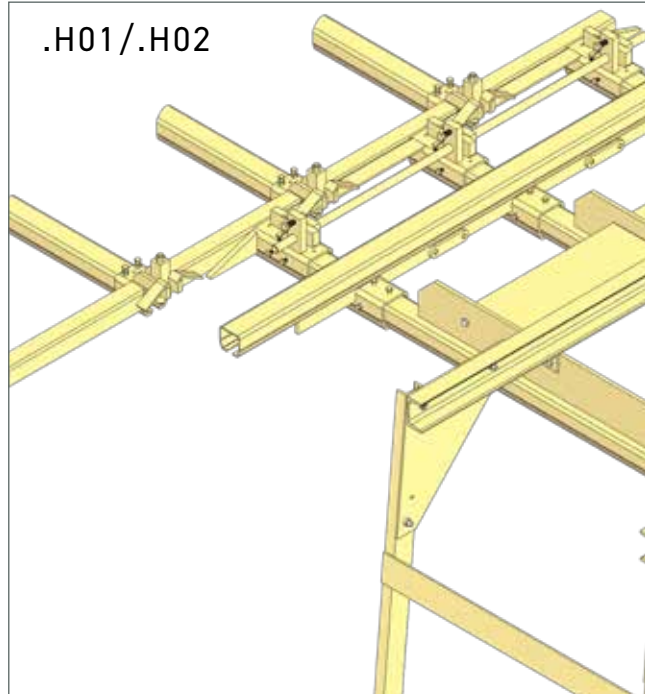
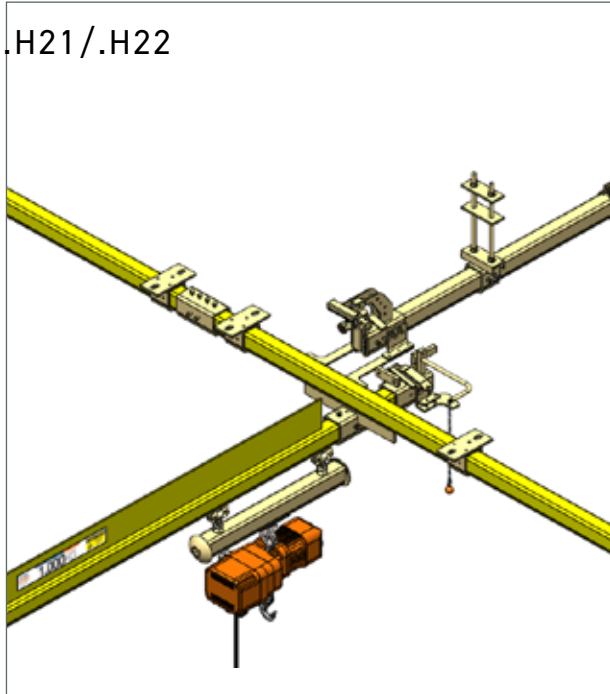

- ✓ Interlocks/latching devices are used to connect a crane with another crane or an extended conveyor system.
- ✓ The load carrying trolley is transferred safely from one system to the other.
- ✓ Only when the bridge and the monorail are linked, the trolley stops unlock, allowing the passage of the carrying trolleys.
- ✓ The loads are moved to separate rooms or work stations.

NIKO Light Cranes options

3. NIKO Monorails with switches & bends

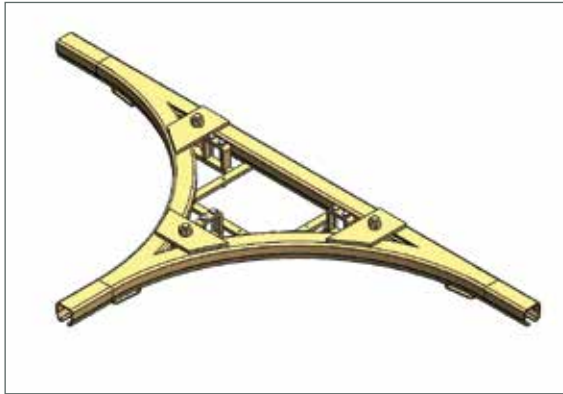
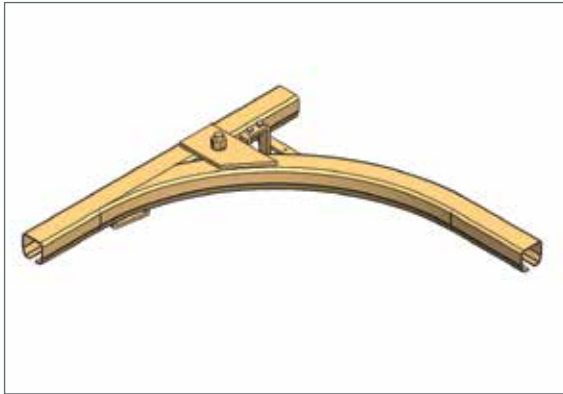

✓ NIKO conveyor systems can be used in a variety of applications utilising more than 2.000 components such as switches and turn tables.

✓ In swivel switches, the switch tongue leads the trolleys in different directions. When a trolley passes through, the tongue switches to the other direction.

✓ Switch with 90° Bend or two bends.

✓ Manual or Automatic swivel switches.



up to 2.000kg



Minimal space requirements



Can be powered

NIKO Light Cranes Applications

Manipulators/Vacuum lifters

NIKO compact track profiles are ideal for this type of application. The rigid mounted NIKO track is perfect for a manipulator with an offset load, the track will not rock, articulate or crab diagonally.



✓ NIKO have trolleys to suit most applications due to being active in the light crane, conveyor and sliding door markets. Other manufacturers will be less flexible with loads trolleys. We can add anti-kick wheels to existing trolleys or work with you to provide a bespoke design.

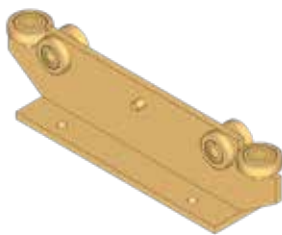

End carriage .T51



NIKO Light Cranes Applications

Tool Suspension

NIKO rigid track can be utilised for tools suspension applications like suspending tool balancers, air balancers, hoists or other equipment. NIKO track system has a significant advantage especially in automotive industry, where accurate load positioning is essential.

- ✓ Perfect for automotive applications
- ✓ Your partner in assembly lines
- ✓ Rigid construction system allows for steadier travel of loads
- ✓ Rigid construction system allows for more accurate load positioning
- ✓ With the rigid construction of NIKO track system, the likelihood of crabbing on bridge travel is considerably reduced





AUSTRIA-
NIKO Vertriebs GmbH
Hainfelder Straße 48
A – 2560 Berndorf
Tel. 0043 (0) 2672 21201
Fax 0043 (0) 2672-21201-13
office.at@niko.eu.com
www.niko.world

POLAND-
NIKO Polska
Skrzynno 192a
Ostrowek 98-311
Tel. +48 504 003 556
info.pl@niko.eu.com
www.niko.world

GREECE-
Helm Hellas S.A.
82nd Km Athens-Korinthos
P.O. Box 209
GR - 201 00 KORINTHOS
Tel. 0030 27410 76800
Fax 0030 27410 25368
info@niko.eu.com
www.niko.eu.com

NIKO Conveyors
597 Middle Street
Bristol, CT 06010
Tel. 001 860-845-8179
info@NIKOconveyors.com
www.nikoconveyors.com

NikoTrack/NIKO US
9 Stockholm St,
Newport RI 02840
C: 401-835-8640
Alex.Koza@niko.eu.com
alex@nikotrack.com
www.nikotrack.com

CANADA -
NIKO Crane Canada
615, rue du Nickel
Québec (Québec) G2N 0J9
Tel. 418 841.2287
info@smakdesign.ca
www.smakmanutention.com

UNITED KINGDOM-
NIKO Ltd
Airfield Park Business Park
Welsh Road East, Southam
Warwickshire, CV47 1NE
Tel. 0044 (0) 1926 813111
Fax 0044 (0) 1926 815599
Sales@niko.co.uk
www.niko.co.uk

USA Light Crane Systems-
NIKORAIL
8000 Joliet Rd.
McCook, IL 60525
Toll Free 888.352.1213
Tel. 001 708-352-1213
sales@hsicrane.com
www.nikorail.com

GERMANY-
NIKO Technik GmbH
Robert-Bosch-Str. 14
DE – 42489 Wülfrath
Tel. 0049 (0) 2058 9093603
Fax 0049 (0) 2058 9093604
office.de@niko.eu.com
www.niko.world

CHINA-
NIKO TRADING (SHANGHAI) Co., Ltd
Room 901-156, No.18
Tianshan Road, Changning District,
P.R.China - 201802 Shanghai
Tel. 0086 134 2785 9785
info.cn@niko.eu.com

www.niko.eu.com

Your **NIKO** agent will be happy to advise you:

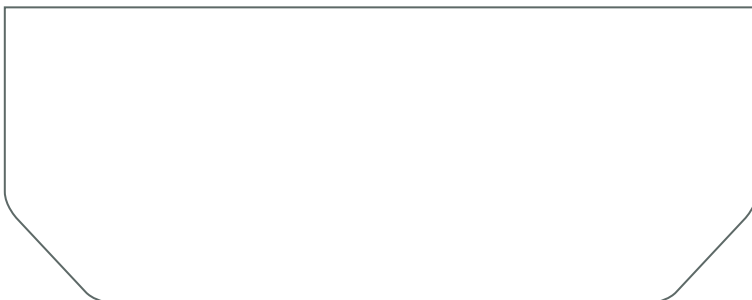

Complete **NIKO** product range:

- LIGHT DUTY SLIDING DOOR HARDWARE
- HEAVY DUTY SLIDING DOOR HARDWARE
- CONVEYOR SYSTEMS
- LIGHT CRANES
- CABLE TROLLEYS, FESTOON SYSTEMS & CONDUCTOR BARS
- PERSONAL FALL ARREST SYSTEMS (EN 795)
- ACCESSORIES FOR GATES AND DOORS